

FESTOOL

1 table. 1000 possibilities.

The multifunction table
MFT 3: arguably the most
versatile worktop in the world.



**Tools for the
toughest demands**

For some people, simply a table.

Practical for laying down tools and papers. Or for making quick notes. Just like all tables. But you expect something different from Festool: Tools and accessories that facilitate your everyday work, developed by experts for practical applications, and which fit into the Festool system perfectly. And all of this in the highest quality.

This is why a table from Festool is not simply a table.



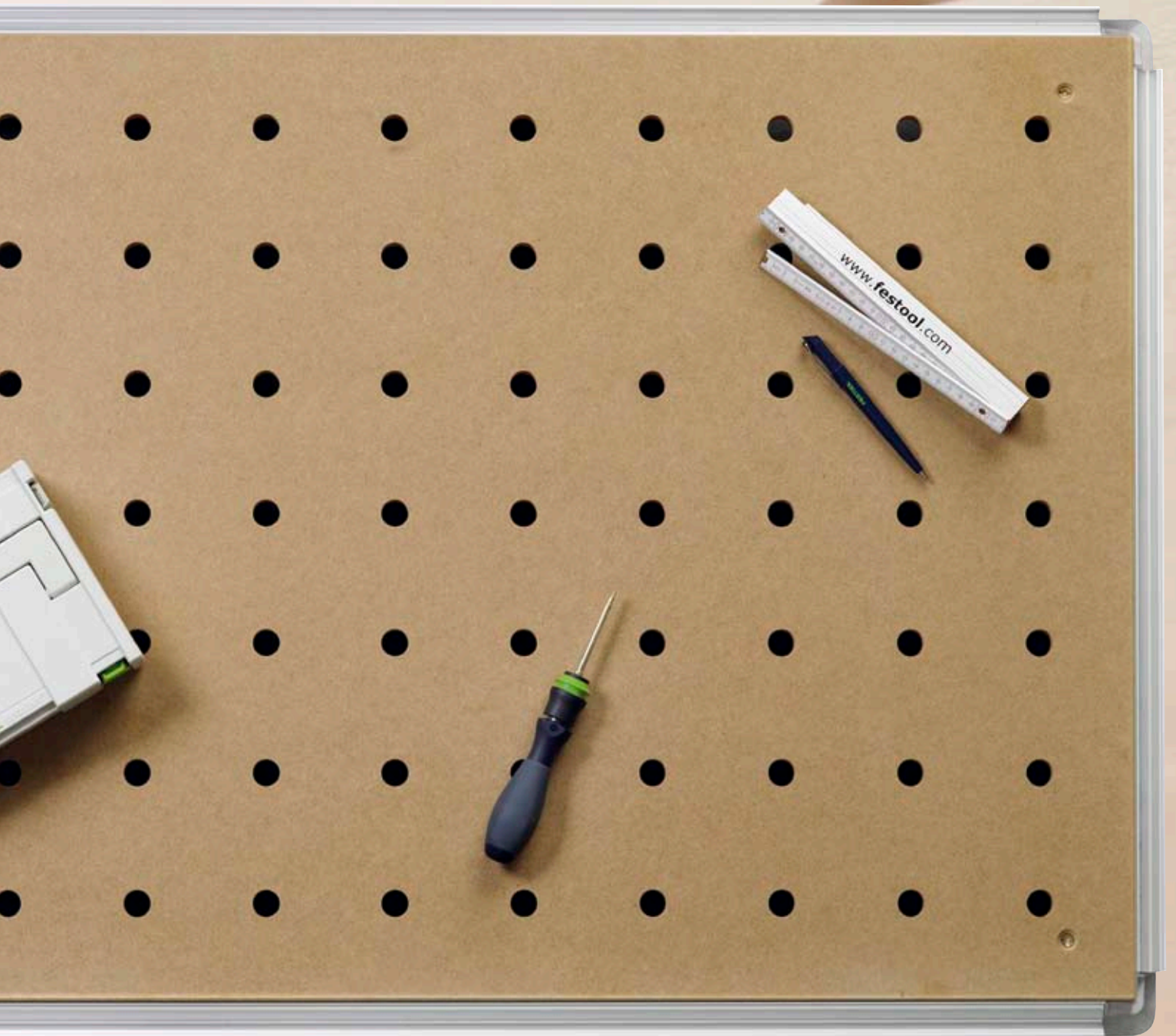

For others it is arguably the most versatile worktop in the world.

The new MFT 3 is a lot more than just a table. It is a work surface that makes absolutely precise work possible. For example, with its guide rail and angle stop. Screw clamps and clamping elements also have a secure hold on your workpiece and the MFT 3 extension can be used to connect all modules from the Compact Module System CMS and many CMS accessory parts. And because Festool has a system concept, it is also compatible with the new vacuum clamping system VAC SYS. In short: a table with 1000 possibilities.



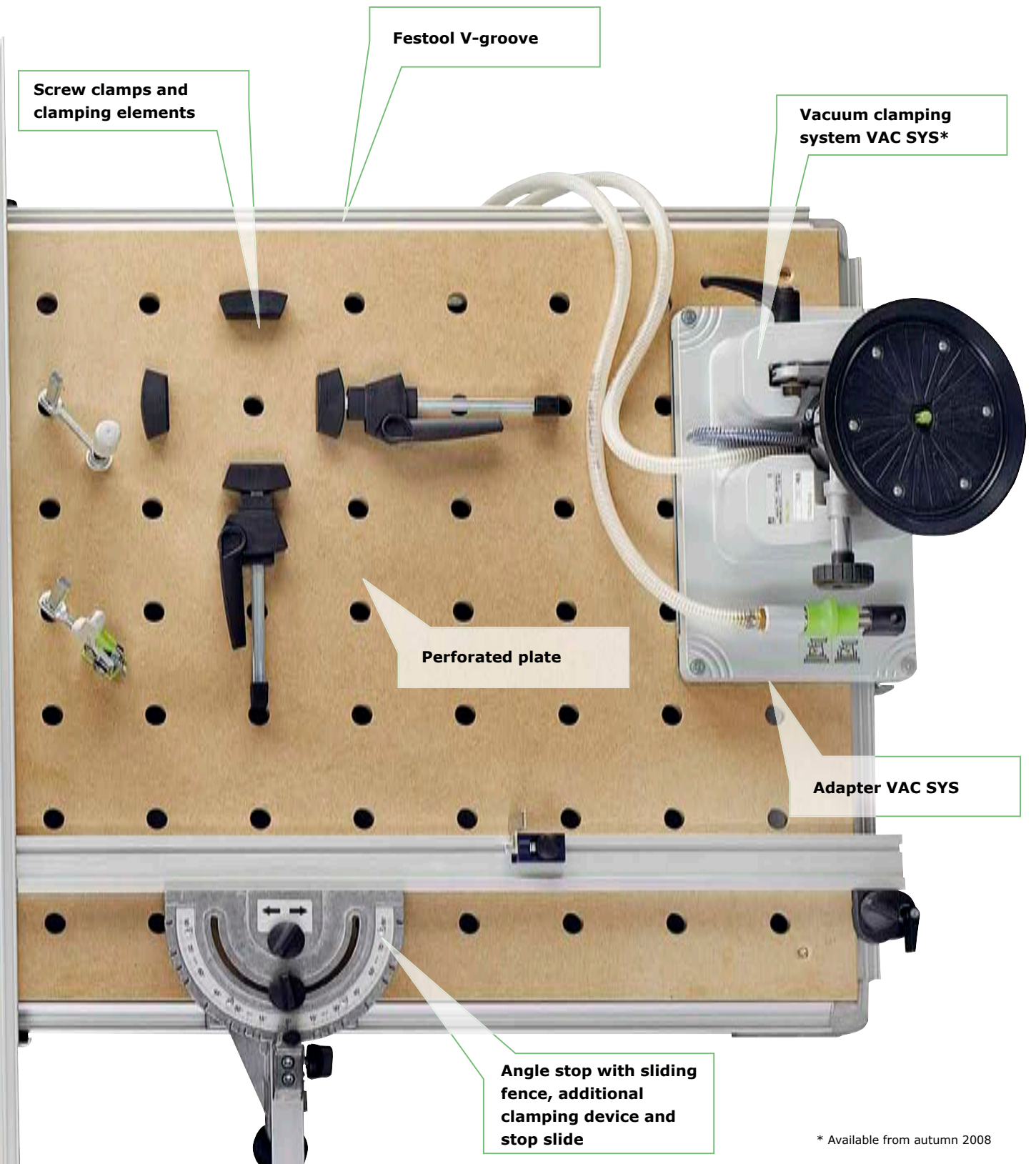

* Available from autumn 2008

The new MFT 3: versatile, precise and mobile.

Flexible work on a secure base.



Precise results.

The guide rail can be set to different material thicknesses and guarantees precise guidance of the Festool jig saw and hand-held circular saw or router – for exact results. You can also safely position and align your workpieces at the angle stop for processing at the correct angle. Repeat cuts and even duplicate production are also possible with the help of the stop slide.

Maximum support.

When sanding, planing, bonding or routing with templates, it is important that the workpiece is held firmly on the table – irrespective of whether it is large, small, angular or round, the MFT 3 offers you precisely this flexibility. The perforated plate allows you to clamp the objects to be processed simply and quickly on the table top with the clamping elements optional. Screw clamps are additionally provided for vertical and horizontal clamping.

Ergonomic and cost-efficient work.

The work height of 90 cm makes ergonomic work possible, which is also easy on the back, even for taller users. Furthermore, the multifunction table MFT 3 can be folded away very easily and is thus ideal for use in the workshop and mobile on-site use.





Extendable work surface

Connecting pieces allow several multifunction tables to be joined laterally with one another. The larger work space thus created permits you to easily clamp and process larger workpieces, or several workpieces at the same time.

Optimised connection to the CMS modular system.

You can use the Festool V-groove to connect the CMS modular system and accessories to the MFT 3. This means that you have circular saws, jig saws, routers and a belt sander available for your work. This increases the versatility of your workplace and you also have the option of executing several steps in sequence without having to reclamp. In short: the MFT 3 becomes a mobile and efficient work station.

Flexible and reliable with the new VAC SYS.

The clamping solution of the future: VAC SYS. This new product gives you the option for the first time of turning your workpieces up to 360° and swivelling them by up to 90° – with a single hand movement. You can now process workpieces from all sides without having to secure the workpiece in a different position. The new vacuum clamping system is connected to the MFT 3 by an adapter plate. If the VAC SYS is not required for a while, it can simply be swivelled away.



The new MFT 3 with system accessories at a glance.

Whether as a table or work bench, the MFT 3 has a lot to offer you.

Use of the guide rail.

The guide rail support can be used to fold up the guide rail or set the guide rail to different material thicknesses.

Ideal work height.

With a work height of 90 cm, the MFT 3 also permits taller users to work ergonomically in a manner that prevents back pain.

Clamping difficult shapes.

Clamping elements provide smaller workpieces with the support required for safe and precise processing.



Optimised system connection.

The MFT 3 extension allows you to use all CMS modules for sawing, routing and sanding.

Ready for use everywhere.

The foldaway legs of the MFT 3 allow it to be folded away to save space and for transportation.



Horizontal and vertical clamping.
Using clamp clips and perforated plate and/or profile section, the workpieces can be secured at any point, simply and firmly.



Extended clamping options.
Through the connection of the new vacuum clamping system VAC SYS.



Compatible with CMS thanks to V-groove.
The new V-groove also permits the use of many accessories of the Compact Module System CMS at the MFT 3.

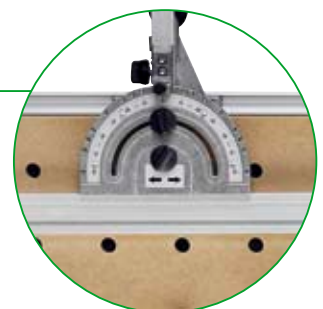

Precise results.
Workpieces can be positioned exactly at the angle stop. The stop slide makes exact repeat cuts and even duplicate production possible. Absolute precision is also guaranteed by the additional clamping device, with which the sliding fence is secured to the V-groove.



Impressive stability.
The additional cross braces make the MFT 3 even more stable and can be folded in easily for transportation.

All things considered: variable work with a system.

Multifunction table MFT 3



Applications

- Safe clamping and securing of different workpieces
- Precise processing of workpieces, also with connection to the Compact Module System CMS
- Extended clamping and securing options through the vacuum clamping system VAC SYS, which can be connected to the MFT with adapters

Strengths and benefits

- Safe sawing and precise routing thanks to the guide rail
- Angle stop, stop slide and additional clamping device ensure exact results
- Ergonomic work positioning thanks to the new table height of 90 cm
- Mobile use of the MFT 3 through space-saving foldaway legs
- Compatibility with Compact Module System CMS
- Festool V-groove permits the use of many accessory parts of the CMS modular system
- Optional connection of the vacuum clamping system VAC SYS
- Ideal connection to the Festool system

Technical data

Work height (folded in)	900 mm (180 mm)
Overall dimensions	1157 x 773 mm
Work surface	1102 x 718 mm
Max. workpiece height (when using the guide rail)	78 mm
Max. workpiece width	700 mm
Drill hole diameter	20 mm
Drill hole pattern	96 mm
Load capacity	120 kg
Weight	28 kg

Version

	Scope of delivery	Order no.
Multifunction table MFT 3	Table with perforated plate and foldaway legs, angle stop, stop slide, additional clamping device, guide rail FS 1080/2 with swivel unit, support unit and deflector, contained in a box	495315

System overview and accessories



System accessories

	Explanations/Dimensions	Order no.
①	Additional clamping device MFT/ 3-ZK For securing the stop rail to the V-groove	495541
②	Stop slide MFT/3-AR For stopping workpieces at the angle stop, can be folded away	495542
③	Cross brace MFT/3-QT For additional stabilisation of the table, qty. in pack: 2	495502
④	Extension MFT/ 3-VL Permits the use of the CMS modules	495510
⑤	Connector VS For joining several MFT 3s	484455
⑥	Perforated plate MFT 3-LP Dimensions: length x width 1102 x 718 mm	495543
⑦	Clamps MFT-SP For attaching workpieces safely and precisely for sawing, sanding, routing, drilling etc., qty. in pack: 2	488030
⑧	Clamps FSZ 120 Polished steel version, clamping range: 120 mm, qty. in pack: 2	489570
⑨	Clamps FSZ 300 Polished steel version, clamping range: 300 mm, qty. in pack: 2	489571
⑩	Lever clamp FS-HZ 160 Polished steel version, clamping range: 160 mm, qty. in pack: 1	491594
⑪	Adapter VAC SYS AD-MFT/ 3 Adapter plate for connecting the VAC SYS to the MFT/3	494977



- Home
- About Festool
- Products
- Woodworking
- Automotive
- Customer Service
- Press Area
- Downloads

Your link to more information...

On our Festool website you can find information about

- the complete product range,
 - detailed introductions of our new products,
 - Dates of Exhibitions and Open Days with Festool,
 - the registration for our Festool Facts online Newsletter,
 - Brochures, price lists, the catalogue and user manuals for you to download,
 - countless product animations,
 - our comprehensive service offer,
 - interesting reports about Festool products from the press,
 - exciting quiz and competitions - always with the chance to win something great,
- and all of this at your leisure.

FESTOOL

TTS Tooltechnic Systems GB Ltd

Saxham Business Park
 Saxham
 Bury St Edmunds
 Suffolk, IP28 6RX
 GREAT BRITAIN
 Phone: +44 (0) 1284 760791
 Fax: +44 (0) 1284 702156
 E-mail: info@festool.co.uk
 www.festool.co.uk

Three Years warranty – that means three years security



Festool grants a 2 year warranty from the date of purchase, as long as the tool has been used correctly. This warranty is automatically extended by a further year, provided that the warranty form with every new tool is completed correctly and returned within 30 days of the date of purchase.

Make a contribution yourself – support the WWF together with Festool!



Our most important contribution to preserving our environment is the quality of our products, which are characterised by their durability and positive eco-features such as recyclability and environmental compatibility.

By purchasing one of the promotional products, you are supporting our collaboration with the WWF and will receive a WWF panda keyring pendant as a thank you gift.

© 1986 Panda symbol WWF – World Wide Fund For Nature (Formerly World Wildlife Fund)
 ® „WWF“ and „living planet“ are WWF Registered Trademarks

www.festool.com/wwf

Type no. 59429



Dealer