

## Assembly & Operating Manual



**TABLESAW MODE**



**CROSSCUT MODE**

### A WORD FROM THE MANUFACTURERS

Thank you for your purchase of the Triton Series 2000 Workcentre. If properly set up, and fitted with a good quality saw and blade, it will give you great accuracy and many years of trouble-free service.

To set up properly, make sure you follow this manual. Otherwise you could spend many unnecessary hours, and still not get it right.

### TERMS AND SYMBOLS USED IN THIS MANUAL

“Front of the Workcentre” refers to the end which has the switchbox. The “left-hand & right-hand side” are when viewed from the front of the Workcentre.

**Safety warning or safety instruction.**

Possible fitting or operating difficulty.

Handy hint & tip.

 Take special note of this instruction.

 **WARNING!** Do not attempt this.

Parts list	2	Test Cuts - Table saw mode	12-13
Basic assembly diagram	3	Test Cuts - Crosscut mode	13-14
Fitting the Triton Precision Saw	4-5	Operating - Table saw	15-23
Fitting other brands of saw	6-7	Operating - Crosscut saw	24-27
Final assembly	8-11	Warranty & Mailing List	28

# PARTS LIST

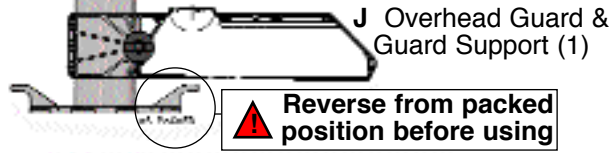
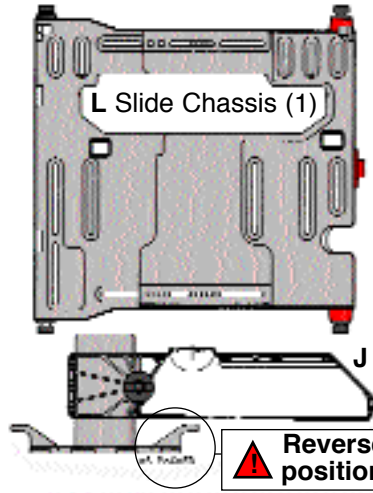
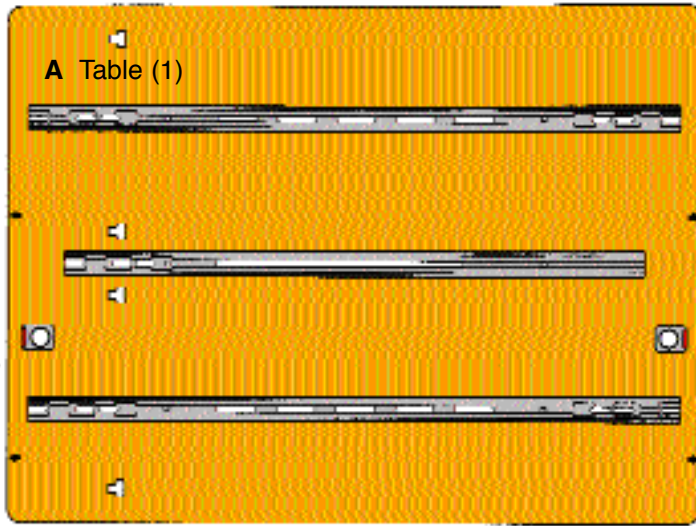

**H Crosscut Fence (1)**

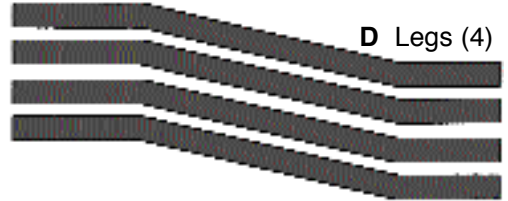
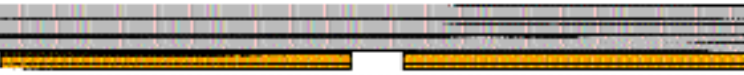
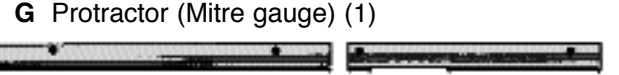
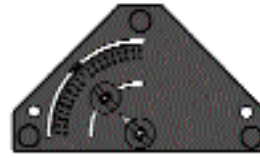
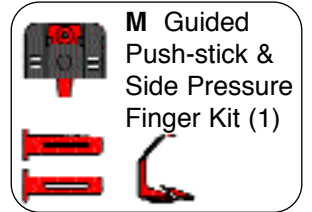
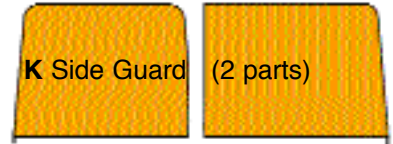

## MAIN FASTENER BAG

**a. Leg Locking Pin (4)**

**b. M8 x 16 Bolt (4)**

**c. M8 Flange Nut (4)**

**d. 8mm Washer (20)**

**e. M8 Nyloc Nut (8)**

**f. M8 x 50 Bolt (8)**

**g. Push-stick hanger (2)**

## SAW CLAMPING HARDWARE (SEPARATE BAG)

**h. M5 Nyloc Nut (3)**

**i. M5 x 8 Screw (2)**

**j. M5 x 25 Screw (1)**

**k. Saw Locators (4)**

**l. Clamping Knobs (4)**

**m. M6 x 40mm Philips-head Screws (4)**

**n. M6 Flange Nuts (4)**

**o. Alignment Cams for Triton Saw (2 sets packed in separate bag)**

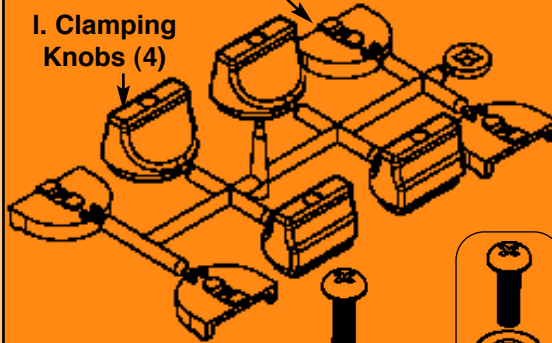

**p. Angled foot (4)**

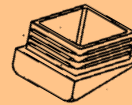

**q. Trigger Strap**

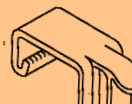

**r. Fence Hanger (2)**



**s. Tube Spanner**

**t. Router Table Fitting Kit**

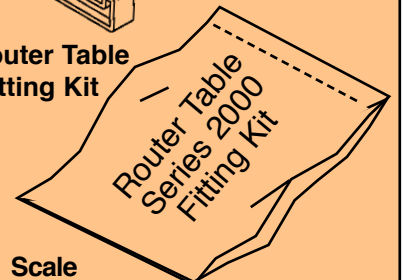

**u. Scale Pointer Labels (1)**

- STEP 1:** Fit the Legs (D) to each End Panel (B & C). Before fitting, check that each leg splays outwards as shown, and that you have fitted the Leg Locking Pin (a) with the spring-loaded ball facing outwards. Tighten the bolts so that the legs are firm, but still free to pivot. Use four M8 x 50 bolts (f), eight washers (d) and four M8 Nyloc nuts (e).
- STEP 2:** Fit the Base Channels (F) as shown. Tighten the bolts until the leg brackets close firmly on the base channels. **Do not overtighten.** The Nyloc nuts used are vibration proof and won't come undone. Use four M8 x 50 bolts, eight washers and four Nyloc nuts.
- STEP 3:** Fit the Flange Nuts (c) inside the Bearing Channels (E) and fit the bearing channels to the end panels. They should click into position when pushed up from below. Fully tighten the bolts. Use four M8 x 16 bolts (b), four 8mm washers (d) and four flange nuts.
- STEP 4:** Fit the plastic components (r, g & p) as shown, and then fit the Rip Fence (I).

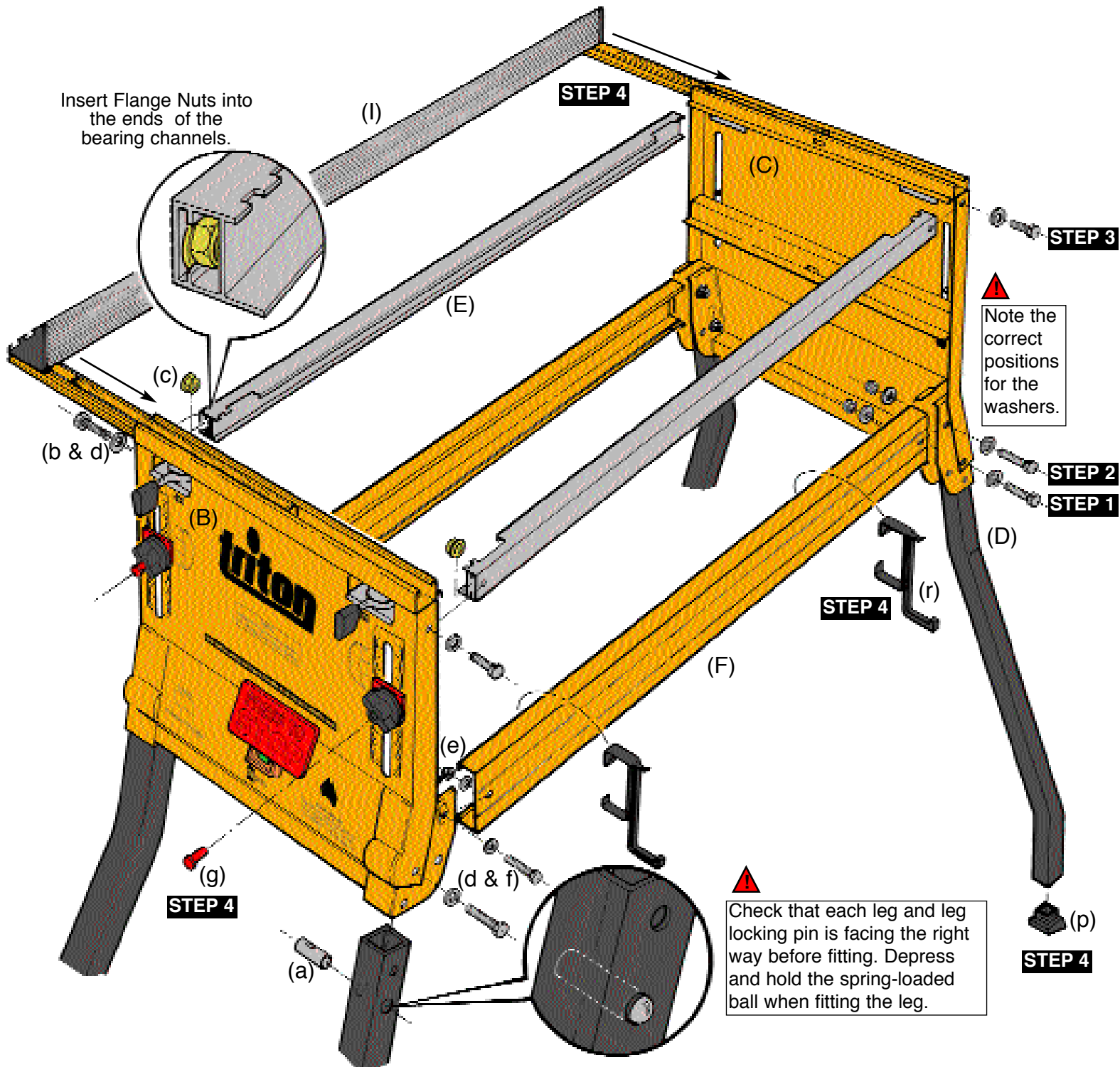

**FENCE LOCKING:** You only need use 2 locking levers - one at the front and one at the back. The locking position of the levers is factory preset. To adjust, simply loosen or tighten the nut at the bottom of each clamp assembly. The levers should reach at least the half way point in their arc of travel before tightening up. Lubricate the cam faces occasionally with light machine oil.

# Fitting the Triton 235mm Precision Power Saw

For other brands of saw go to Page 6.

## FITTING THE SLIDE CHASSIS

Place the Slide Chassis (L) in the bearing channels with the red plastic catch and red bearing spacers closest to the front panel (the switch box end) and the flanges upwards. Enter two bearings in the channel cutouts. **1** Slide the chassis towards the rear panel and the other bearings will drop in. **2**

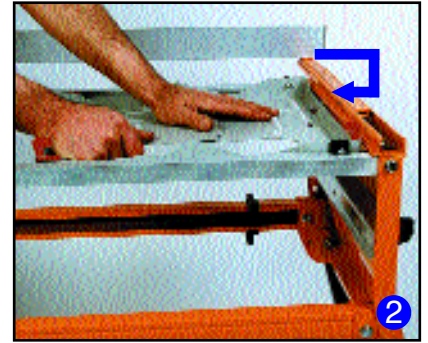
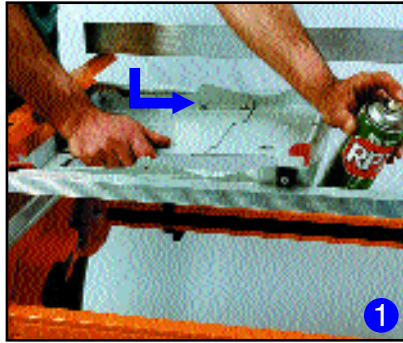

Spray the channels with RP7 or WD40 for a smooth slide.

## FITTING THE TRITON SAW

Unplug your saw. Check that the blade is set at 0° and at full depth of cut.

Fit the Saw Alignment Cams (o) from below **3**, holding the bases in the rectangular slots while you screw into them. (They cut their own thread.) Make sure the lines moulded on top of the cams are both pointing towards the rear panel. Tighten the screws until nipped gently. **4**



## FITTING THE SAW LOCATORS AND KNOBS

Fit the saw into the chassis with the alignment cams locating in the holes in the saw base-plate.

If the saw is set at full depth, the saw's spring-loaded guard will be held in the retracted position by the back edge of the chassis cutout.

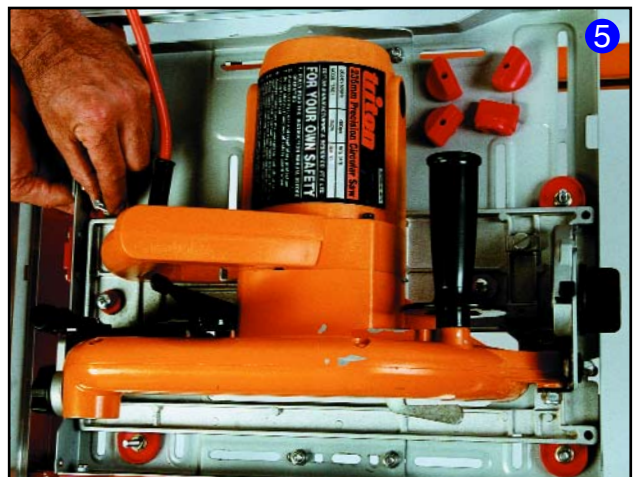

Break or cut the Saw Locators (k) and Knobs (l) from their moulding "tree" and carefully trim off any remnants with a sharp knife. Fit the saw locators in the slots shown in **5** using 4 Philips-head screws (m) and Flange nuts (n). The straight edges should be against the baseplate, but spaced away from it slightly to allow for final saw adjustment. (Use a spatula blade **6** or a piece of cardboard or metal about 1 mm thick as a spacer.) Firmly tighten the screws.

Screw the knobs on (they cut their own thread) until they just scrape against the top edge of the saw base-plate. **7** This tension is sufficient to hold the saw upside-down for final adjustment, and still allow the saw to be shifted sideways slightly using the alignment cams.

Check that the saw is securely mounted. Turn the slide chassis over, re-engaging the bearings in the channels. **8** & **9**



# Fitting the Triton 235mm Precision Power Saw (cont.)

## ALIGNING THE SAW

Position the chassis halfway between the end panels. Adjust the fence in close to the blade and lock it. Make sure the blade is vertical by comparing it to the face of the fence. If necessary, loosen the nut holding the Blade Angle Trimmer (circled), and adjust the blade angle. Re-tighten the nut. ①

Use the saw's spanner ② or the Tube Spanner (s) to rotate the cams until the front and rear of the blade are *just touching the fence*, when it is at 0 mm. When satisfied with the position tighten the alignment cam screws. ③

Unscrew the front handle of the saw for better access to the front cam. Lower the blade for access to the rear one.

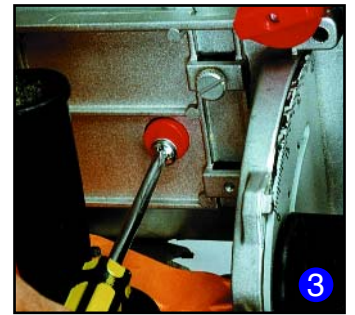
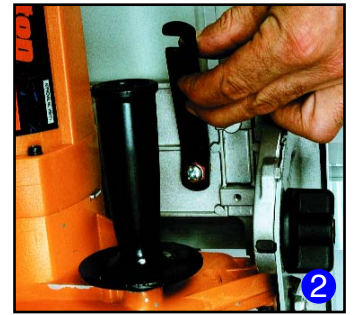

## FINAL CLAMPING OF SAW

Double-check the saw position by now locking the fence at 0 mm, and trying to turn the blade backwards by hand. The teeth should *lightly* scrape against the face of the fence. ④ If not, repeat the above alignment.

This is a very important step, because it will ensure that your saw cuts are true, and that your fence scales are accurate, so take your time.

When satisfied with the position of the saw, reposition the saw locators hard up against the edge of the baseplate, as follows. Hold each knob against turning and loosen the screw about half to one turn. Push the saw locator into position, and firmly tighten the screw. ⑤

Turn the saw right-way up again and loosen the four knobs a couple of turns. Check that the saw cannot move sideways at all, and that all screws are fully tightened. Do up the knobs again, perhaps one turn beyond when they first scrape on the baseplate.

The saw is now set up, and is available at any time for hand-held use by simply loosening each knob half a turn and lifting the saw straight up. ⑥ If the locators are correctly fitted, the saw will go back into exactly the right spot each time.

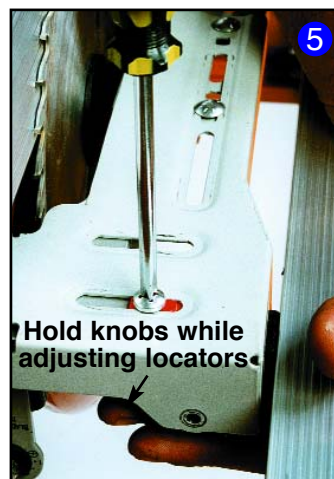
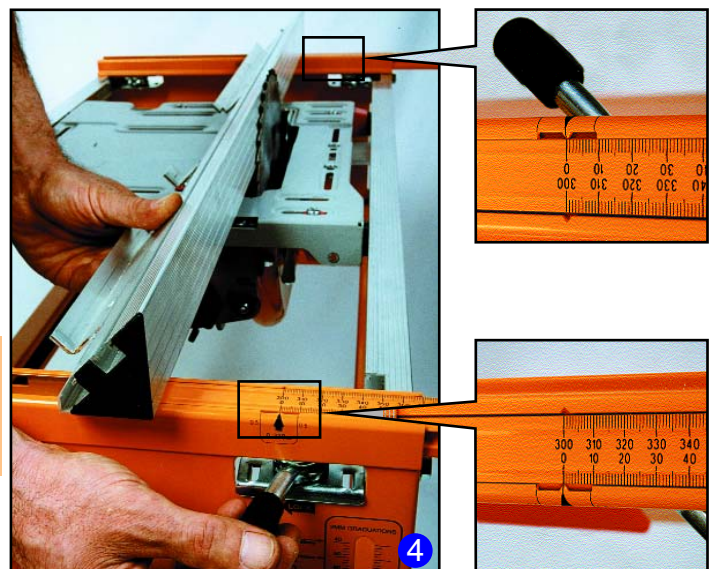

Triton saw owners, please skip to Page 8.

# Fitting other brands of power saw

## FITTING THE SLIDE CHASSIS

Place the Slide Chassis (L) in the bearing channels with the red plastic catch and red bearing spacers closest to the front panel (the switch box end) and the flanges upwards. Enter two bearings in the cutouts in the channels. ① Slide the chassis towards the rear panel and the other two bearings will drop in. ②

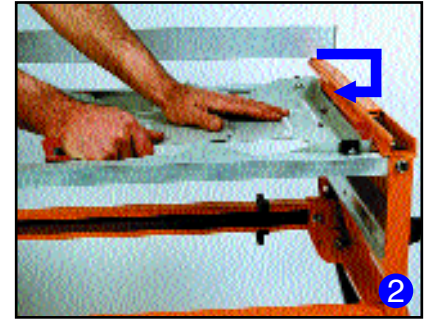
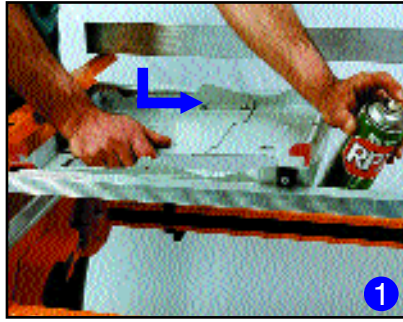

Spray the channels with RP7 or WD40 for a smooth slide.

## ADJUSTING THE SLIDE CHASSIS

Check that your saw is unplugged, make sure the blade is set at full depth of cut, and is set at 0°. Study ③ below [especially if you have a small (184mm) saw] and follow steps 1 to 5 as required.

1. Adjust the slide chassis to the shortest length which will suit your saw, and provide widely spaced slot positions on the baseplate edges for fitting the clamps. (In shortening the chassis, do not overlap any of the mounting slots. If relocating the four coach bolts, use the square holes.)
2. Position the saw as far forward as possible on the chassis, but allow for finger access to the front wing-nut or knob on the saw.
3. Don't obstruct the sawdust opening in front of the saw blade.
4. Try to have the blade nut no more than 170mm from the front of the chassis.
5. For small saws, bolt a thin wooden spacer (eg. 6mm ply) behind the saw, to prevent possible saw movement.

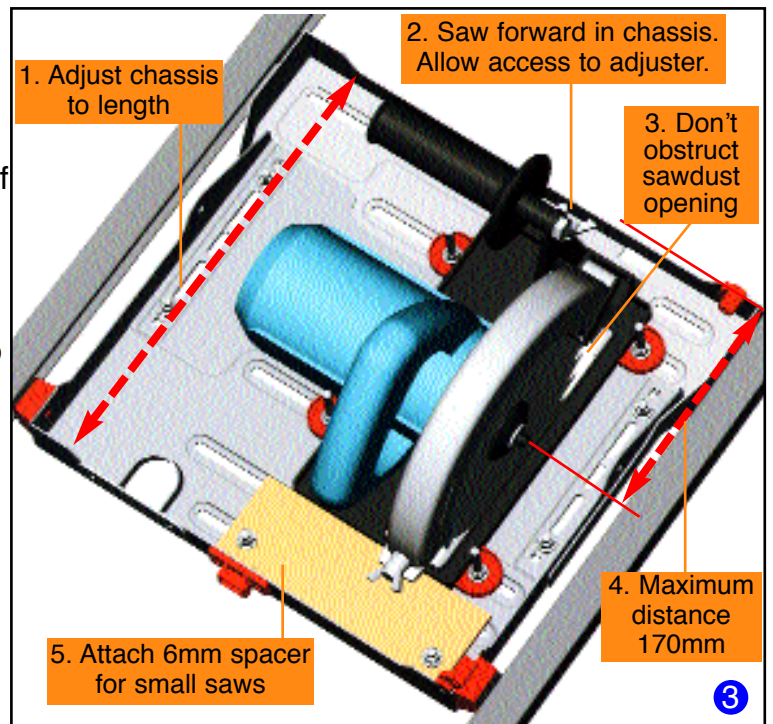

## FITTING THE SAW LOCATORS

Break or cut the Saw Locators (k) and Knobs (l) off their moulding "tree", and trim any remnants with a utility knife.

Fit the saw locators in the selected slots, with their straight edges against the base-plate using four M6 screws (m) and Flange nuts (n). Firmly tighten up the screws using a screwdriver from below. ④



The spanner shown is optional, as the Flange nuts are self-gripping.

## FITTING THE CLAMPING KNOBS

Screw the knobs on (they cut their own thread) until they scrape against the top edge of the saw base-plate. ⑤ Leave the knobs with the cutaway sections facing away from the saw.

Check that the saw is securely clamped, and turn the slide chassis over, re-engaging the bearings in the channels. ⑥ & ⑦

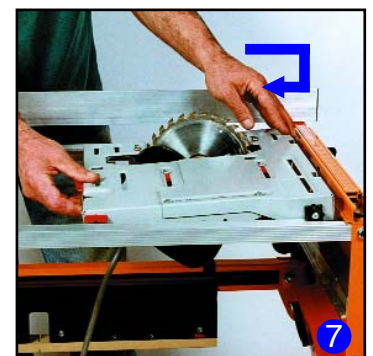
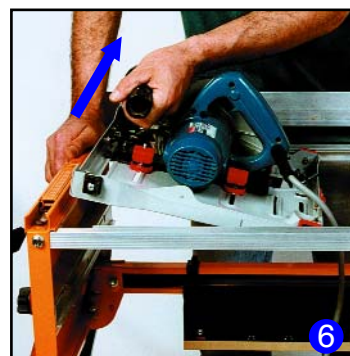

# Fitting other brands of power saw (cont.)

## ALIGNING THE SAW

Have the chassis midway between the end panels and lock the rip fence close to the blade. Compare the blade angle to the vertical face of the fence, and if necessary adjust the blade angle (using the saw's adjuster) until they are parallel vertically.

Hold the clamping knobs to stop them turning and use a screwdriver to loosen the clamp assemblies - *half to one turn only*.

Push the saw locators to move the saw. ① Do not push the saw itself as this may dislodge the clamps.

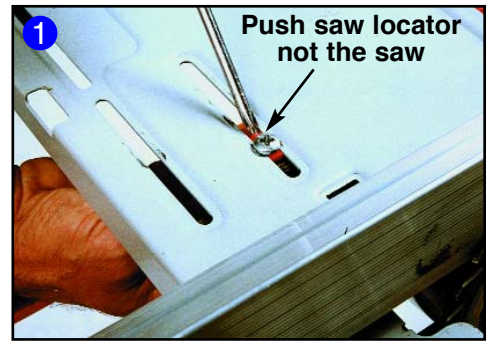

Lock the fence at "0" front and rear and align the saw so that the blade is *just touching* the fence. Spin the blade backwards by hand. The teeth should lightly scrape against the fence. ②



This is a very important step, it will ensure that your saw cuts are true, and that your fence scales are accurate, so take your time.

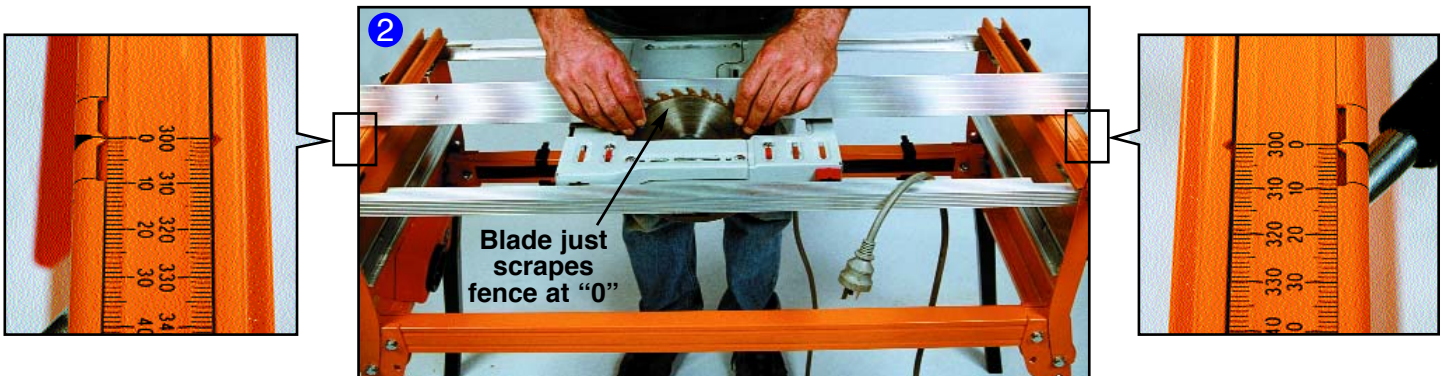

## FINAL CLAMPING OF SAW

Check that each saw locator is pressed up against the baseplate, hold the knobs against turning, and firmly tighten the four screws.

Remove the fence and turn the saw rightway up. Undo the clamping knobs a couple of turns and check that you cannot move the saw sideways at all between the locators.

Do up the knobs, and this time you can tighten them more firmly, perhaps one turn beyond when they first scrape on the base-plate. ③

If you tighten any one knob too much, and can't loosen it, undo the other three knobs by half a turn, remove the saw and undo the knob.

Turn the saw upside down again, re-fit the fence and double check that the blade is still at "0".

The saw is now set up, and is available at any time for hand-held use by loosening the knobs half a turn and lifting the saw straight up. If the locators are correctly fitted, the saw will go back into exactly the same position each time. ④

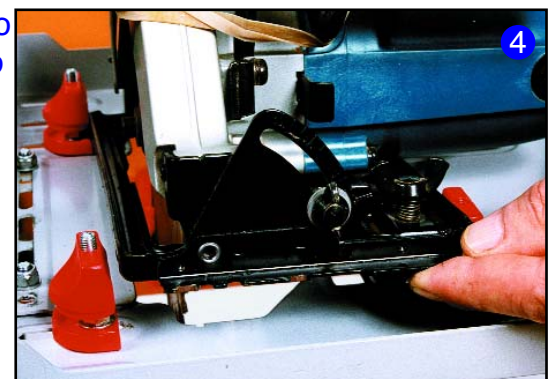

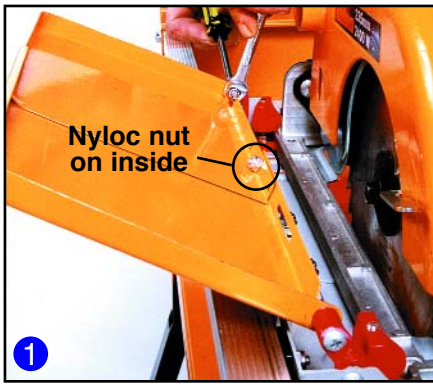

## FITTING THE SIDE GUARD

Slide the two sections of the Side Guard (K) together until they fit between the pivot brackets on the slide chassis. Loosely fit the short Philips-head screw (i) and a Nyloc nut (h) to hold them together.

Fit the two longer Philips-head screws (j) and Nyloc nuts through the pivot brackets and into the guard flanges. ① Tighten until the guard is firm, but still free to pivot. Finally, tighten the screw holding the two halves together.

## FITTING THE TRIGGER STRAP

**!** Before fitting the trigger strap (q) always ensure that the saw is disconnected from the power and that the switch on the Workcentre front panel is in the "OFF" position.

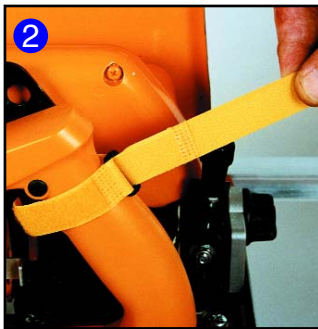

Wrap the Trigger Strap (q) around the handgrip with the furry side facing outwards. Pass the strap through the buckle, until the security loop has passed through. ② If your saw has a safety lock-out button press it and then tighten the strap until the trigger clicks "ON".

Wrap the free end of the strap around the handgrip. ③

With most saws, the strap can be slid on and off the saw trigger, without undoing it each time.

Do not leave the trigger strap permanently locked on. When you have finished work for the day, release the strap and allow the spring in the trigger to relax.

## FITTING THE TABLE

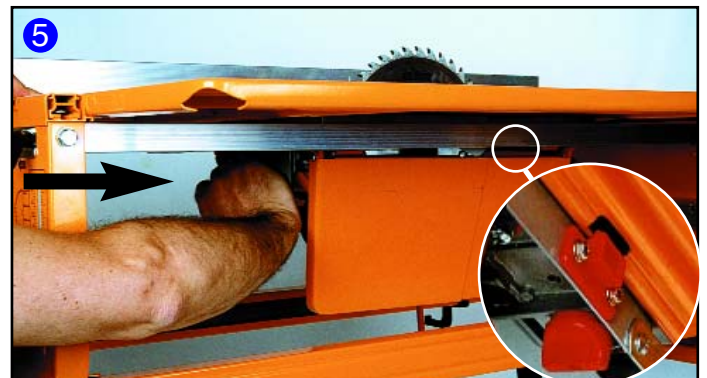

Turn the slide chassis upside down. Position it roughly half-way between the end panels. The front of the saw must be facing the front panel (switchbox end).

Lower the Table (A) over the blade, with the four T-slots closest to the rear panel. ④ Line up the arrows on the edges of the table with the scale pointers on top of the end panels. Push the table latches to the "LOCK" position. The red indicators disappear from view when the latches fully locate.

Reach underneath and push the slide chassis towards the rear panel until the red catch (shown in the inset view on ⑤) "clicks" home and locks the chassis underneath the table.

## FITTING THE OVERHEAD GUARD & SUPPORT

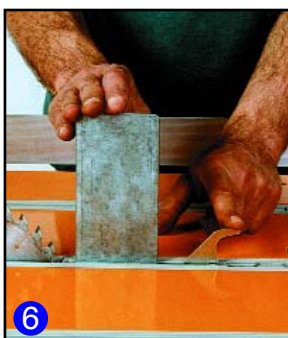

Loosen the knob on the Overhead Guard (J) to remove the Guard Support from its shipping position. Fit the support to the centre table slot, using the cut-outs at the end. Ensure the saw blade is adjusted to its maximum depth, then position the support about 12mm behind the blade and lock it in by pressing the locking lever down. ⑥

Lubricate the entry if it's a tight fit. Check the guard support is reasonably square to the table, and adjust it if necessary by pushing evenly with your hand or a block of wood. ⑦



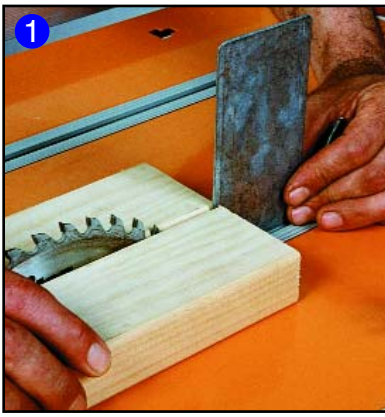

Hold 2 straight pieces of wood lightly against the blade. ① The overhead guard support should fit between the pieces.

If not you may have to adjust the saw position slightly. This is only likely if you have a very thin kerf blade (2.0 - 2.2mm cut width)

Fit and lower the guard. ② Spin the blade by hand before connecting the power to ensure it is not touching anything.

**!** Always make sure the blade is at full height, the guard is fitted, and the table is locked to the end panels before switching on the power.

Check that the teeth on your blade are pointing in the same direction as the etched symbols on the guard. If not, you have incorrectly fitted the blade to your saw.

## CONNECTING THE POWER

Make sure the switch is "OFF", plug the saw into the switch box, and bring power to the switch box via a 10 Amp extension cord.

Press the green switch with your finger to switch the power "ON". ③ Tap the stop plate with your hand or knee to switch "OFF". ④



Switch the power on and off and watch the blade. If it quivers sideways on start-up it's a sign of a worn arbor in your saw, or excessive slack in the mountings between the motor and baseplate.

If the blade vibrates significantly at full speed or on slow-down, it's either buckled or not seated properly on the arbor. Check the flatness of the blade with a straightedge, check the fit of any arbor-reducing washers, and check for resin/sawdust build-up on the arbor or flange washers.

A slight quiver is generally noticeable on slow-down in most blades, and shouldn't affect your cuts.

## FITTING THE BEVEL GUIDES

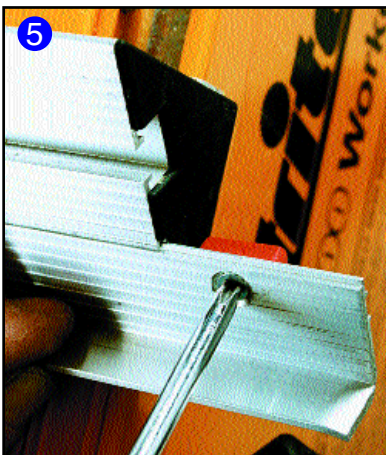

Reverse the fence so that when fitted to the Workcentre from the left hand side, the 45° face is closest to the blade.

To fit the Bevel Guides (N), loosen the Phillips-head screws slightly, engage the lip at the top of each guide in the mating section of the rip fence, and guide the red plastic clamping feet into the T-slot. ⑤

The plain bevel guide fits in front of the blade. The notched bevel guide fits at the rear, with the small tab locating between the blade and the overhead guard support. (If your power saw is fitted with a riving knife remove the small tab (circled) from the guide using a hacksaw.) ⑥

Tighten the Phillips head screws. The function of the guides is described on 20.



## SETTING UP THE CROSSCUT MODE

Remove the overhead guard and rip fence and store them as shown on Page 28.

Remove the table and place it to one side for the moment.

Adjust the height of the aluminium table support rails inside the front and rear panels, to suit your saw. ①

The rails are meant to be a snug fit inside the panels and may need a sharp tap to free them. The adjustment is a bit easier without the table in position.

The four most common saw sizes are printed on the end panels for reference. In ① the table height is being set for a 235 mm (9 1/4") saw. The top edge of the red indicator is the reference.



Turn the saw right way up but leave two of the bearings on top of the channels. ② Slide the table in from the side until the centre slot is directly below the blade. Lock the table by pushing the latches fully home into the cut outs in the table support rails. (The red indicators on the latches must fully disappear from view).

Slide the chassis to the rear panel and the two free bearings will drop into the channels.



**Always make sure that all four bearings are back inside the channels before making a cut.**

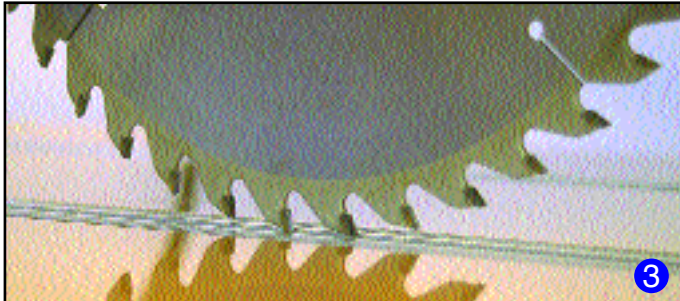

The tip of your blade should be just entering the slot (by 1 - 2 mm) and it should be approximately central in the aluminium track. ③ If not, see Saw Slump adjustment on Page 13.

Leaving two bearings out of the channels enables you to slide the table in from the side without the tip of the blade scratching the paintwork on the table. Another method is to raise the saw blade a little, and then lower it again when the table is in position.

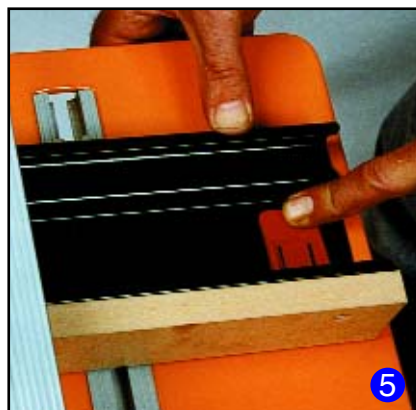

## FITTING THE CROSSCUT FENCE

Fit the Crosscut Fence (H) to the four T-slots in the table, with the MDF sub fence closest to the saw. Pull the fence towards the rear panel as far as it will go. ④

To release the fence, hold down each red plastic catch while pushing the fence towards the saw. ⑤

The fence may be a little tight - especially when new. Do not loosen the screws fastening the four plastic feet. Rather use a block of wood to gently tap the fence home. If you do have to loosen the screws, 1/4 to 1/2 a turn should be enough. The plastic feet are difficult to re-seat if undone.

## USING THE RIP FENCE SCALES



Each end panel has two scale pointers exactly 300 mm apart. For cuts in the range 0 - 320, (with the fence on the left of the blade) use the pointers which are closer to the blade. Line up the arrow point and read the lesser figure on the scale arms.

For wider ripping in the range 320 - 620mm simply move across to the outer scale pointers and read the higher figure.

In ①, the fence is set at 100mm using the 0-320 mm pointers. It would be 400 mm if you were using the outer pointers.

The edges of the pointer cutout, and the two fine 0.5 lines are 9.5mm from the arrow-point. Use them as a vernier in setting 0.5 mm increments, to avoid guessing the mid-point between graduations.

## USING THE RIP FENCE ON THE RIGHT



Set on the left of the blade, the fence gives the maximum 620mm capacity. However, if you prefer to use the fence on the right, the self-adhesive Scale Pointer Labels (u), will provide the zero position.

Fit the fence on the right and touch it against the blade. Check it is **exactly** parallel by comparing the readings at the front and rear panels - about 183mm / 483mm. Lock the fence, turn the blade backwards by hand and the teeth should lightly skim the fence.

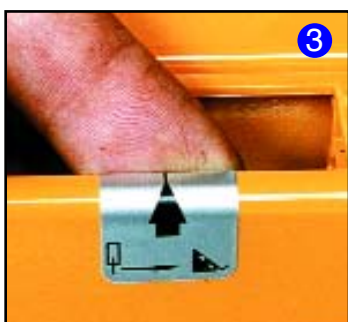

Remove all dust, and apply the labels to the specified end panels directly in line with the 0 marks on the scale arms.

The labels wrap inside the tracks to prevent peeling off. Lines printed on the labels show where to fold. ② Once they're stuck in position, slide the fence away to fold the tops of the labels inside. ③

You can reverse the bolt and knob in the overhead guard for closer fence access if using the fence on the right.

## FITTING THE GUIDED PUSHSTICK AND SIDE PRESSURE FINGER

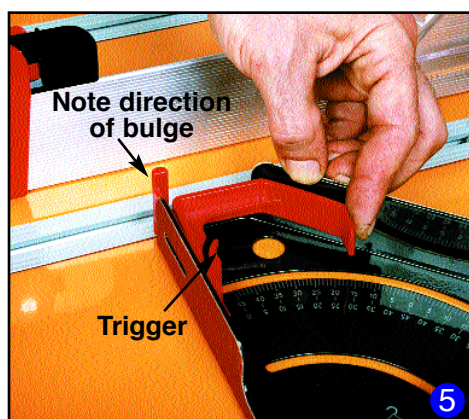

The Guided Pushstick slides in the T-slot on the 45° face of the rip fence. The swing-arm rests against the vertical face, and should pivot freely. ④

The lock direction of the swing-arm can be reversed (depending on which side of the Workcentre the rip fence is used) by firmly pressing the direction switch.

Clip the Side Pressure Finger to the holder, noting the correct orientation of the bulge ⑤. Snap the assembly into the left-hand corner of the protractor. Pull the finger out to lock. Press the trigger and push the finger in to retract.

In use, the finger is extended and the protractor locked at an appropriate angle to press the wood against the fence in front of the blade. The protractor must be locked in it's slot by loosening the locking knob, rotating the pointer to the  $\square$  position, and re-tightening. (See also ⑥ Page 12)

A spare finger is included in case you accidentally cut one.

# TEST CUTS - Tablesaw Mode



It's important that you perform these test cuts, in the order laid out in these two pages.

First, check your square - many are inaccurate. Use a board with a straight edge. Press the square firmly against it, and use a sharp pencil to trace the blade on the board. ① Flip the square over, press it against the straight edge again, and compare the blade to the pencil line. ② Any error in your square is seen as doubled.

## CROSSCUTTING TEST

Take a **straight** piece of wood 30 - 45 mm thick and at least 300mm long. Lower the overhead guard to about 5mm above it.

Fit the protractor to the left or right table slot, and check that it slides freely from end to end. Spray lubricant such as RP7 on the slider strip. Set the protractor at exactly 0°, and tighten both knobs.

Hold the wood firmly against the long sand-paper face of the protractor, and push the protractor down lightly for best guidance in the slot. ③ Feed the wood smoothly into the blade.

When the workpiece is past the back of the blade, switch off by bumping the STOP plate.



If the *back of the blade* re-cuts or burns the workpiece, your saw is probably slightly skew on the slide chassis, and may have to be adjusted slightly. Or your blade could be buckled.

## CHECKING THE CUT



For an error **ALONG** the cut, ④ re-adjust the protractor angle slightly and repeat the test. (Hold the square against the edge that was against the protractor face).

For an error **ACROSS** the cut ⑤ (with the square against the face which was on the table) adjust the blade angle slightly.

If your saw does not allow you to get the blade completely square to the table, either file out the curved slot in the saw's quadrant, or attach shim packing between the narrow edge of the saw baseplate and the slide chassis to angle the whole saw slightly. The Triton Saw Stabilising Bracket (see next page) is advised if the blade reaches 90°, but then slumps away because of saw flex.

## RIPPING TEST

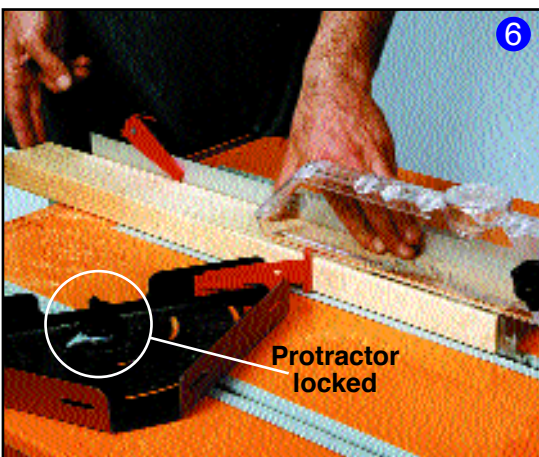

⑥ Take a straight piece of wood at least 70mm wide and 500mm long, and adjust the overhead guard to about 5mm above it. Lock the rip fence exactly parallel to the blade at a fence setting to give an off-cut of say 5 mm.

Fit the guided push stick and side pressure finger as shown in ⑥. The protractor must be locked in the slot (as circled) about 20mm in front of the blade, and at an angle to gently flex the finger. Avoid applying too much pressure.

Hold the wood firmly down on the table and feed it smoothly. Keep pushing it - without pausing - until it is fully past the back of the blade. Use your hands while it is safe to do so, but finish off using the guided push-stick to push the wood through.

If the back of the blade re-cuts or burns the workpiece, either the fence was not parallel, or the saw needs adjustment on the slide chassis, or the blade is buckled.

If the wood tightens up between the overhead guard support and the fence, switch off and wait until the blade stops before withdrawing the piece. Increase the rear fence setting *slightly* and repeat the cut. An extra 0.5-1mm on the rear fence settings is okay to prevent jamming.

## TEST CUTS - Crosscut Mode

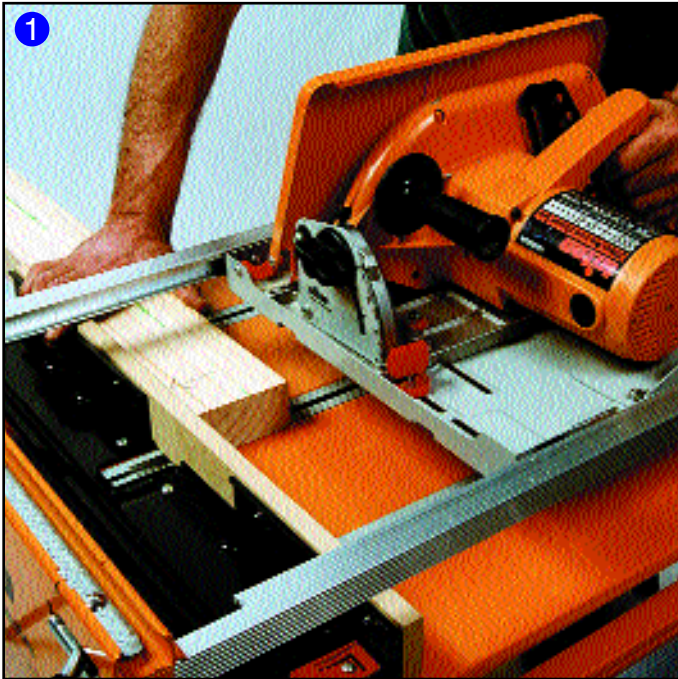

Unlock the trigger strap and use the trigger normally. **With the power off**, push the saw from end to end, to check that the blade tip is clear of the table slot.

Take a straight piece of wood, at least 300 mm long, hold it with your right hand, and push the saw with your left. **1** Hold the wood firmly, pushing it down on the table and against the fence. Check the blade is not touching the wood before switching on.

Gently and smoothly make the cut, without forcing the saw. If you have to push hard, or if there's a burning smell, sharpen or replace the blade.

**Avoid pulling a spinning blade back towards you. The offcut - especially a small one - could be re-cut by the back of the blade, with a bang!**

If the blade marks the work piece as it is slowing down, simply pull the wood out sideways once you've cut through.

If you can't complete your cut, because the blade tip doesn't quite reach the crosscut fence, either raise the table slightly, or move the saw slightly forward on the slide chassis, or pack out the MDF subfence.

Remove any uncut fibres, and check for accuracy as described earlier.

For an error **ALONG** the cut, check that the fence was fully home in the T-slots and that there was no sawdust between the wood and the fence. Always hold the square against the edge that was against the fence.

For an error **ACROSS** the cut, you probably have some "saw slump", or flex between the saw motor and its baseplate. You have four options to rectify the problem:



1. Build a compensating angle into the table position, so that the table remains square to the blade. In **2**, the table support rails are set at 72mm on one side, and 80mm on the other.

2. Obtain the Triton Saw Stabilising Bracket **3** (ABA020) which provides a strong brace for the motor, yet still allows easy blade height and angle adjustments;

3. Upgrade to a saw with better motor mounts;

4. Adjust the blade angle slightly every time you convert between modes.



If there's a step in the cut, or a high spot or a burn mark, see *Arbor float* on Page 14.

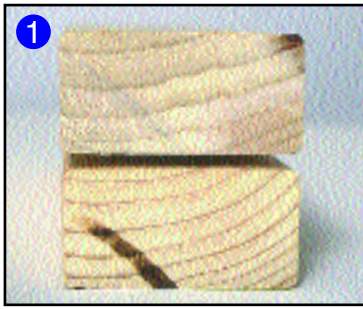

## ARBOR FLOAT

If your cuts have ridges, burn marks or high spots **1**, the saw is mounted skew on the slide chassis, or it has arbor float, or the blade is blunt / buckled. Check for arbor float by unplugging, gripping the blade or blade nut, and pulling in and out in the direction of the shaft. **2** Any movement is undesirable.

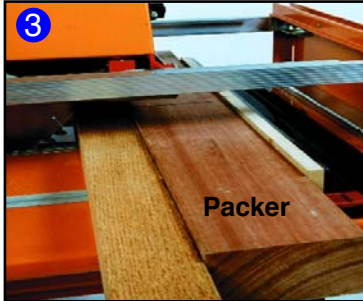

For perfectly square cuts, you may have to repair or upgrade your saw.

You might reduce the problem by placing a parallel-sided packer between your work and the fence. **3** Also try shaving cuts, **4** where the second (shaving) cut removes say 1 mm of material, putting less load on the arbor.

## SELECTING A CIRCULAR SAW

A float-free arbor, and firm mountings between the motor and baseplate, are most important.

Check for arbor float as described above. To check the mountings, hold the baseplate down on a flat surface, and see how much you can move the motor up and down. Test at different height and angle settings.

Most circular saws have a height adjustment pivot at the front, with the locking lever/knob behind the motor. They are the preferred type. Vertical lift (plunge-type) saws should only be fitted if they remain rigid and accurate throughout their height and angle adjustment range.

A 235mm (9 1/4") saw is best for heavy work, requiring a large depth of cut or extra power. 208mm (8 1/4") or 185mm (7 1/4") saws are quite adequate. If considering upgrading your saw, the Triton 235mm Precision Power Saw is highly recommended.

## SELECTING A SAW BLADE

This is one of the key factors for square, smooth cuts with a minimum of splintering. We strongly recommend tungsten carbide tipped (TCT) blades.

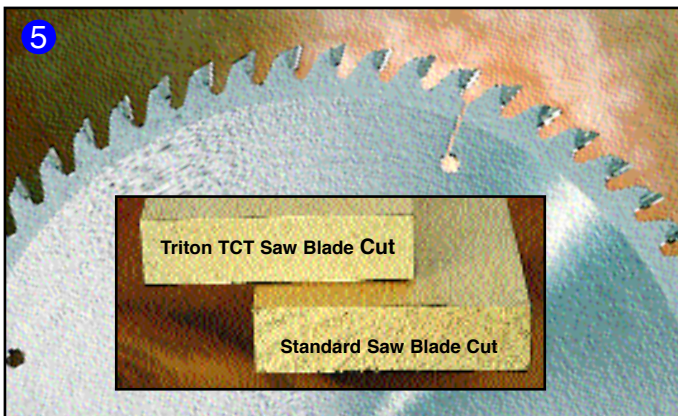

Triton Premium TCT Saw Blades have been expressly designed for the Workcentre and have a unique tooth design. They cut very cleanly, reduce arbor float-related problems, and minimise splintering, especially in veneered boards.

The number of teeth depends on the work you'll mainly be doing: for crosscutting, the more teeth the better. A 184mm saw should have 30 - 40 teeth and a 235mm saw should have 40 - 60 teeth.

Ripping generally requires fewer teeth, (20 - 32 on a 235mm blade), with larger gullets behind the teeth to help clear the longer curls of saw dust created when ripping natural timbers.

If you can only afford one blade, we suggest more teeth rather than fewer. Just slow down the feed rate when ripping natural timbers.

# OPERATING - Tablesaw Mode

**!** It is important that you practice the following safety rules at all times.



**Always keep fingers well clear of the blade.** Fit the overhead guard as low as possible, to just allow the work to pass under. Where possible use the guided pushstick and side pressure finger. **1**

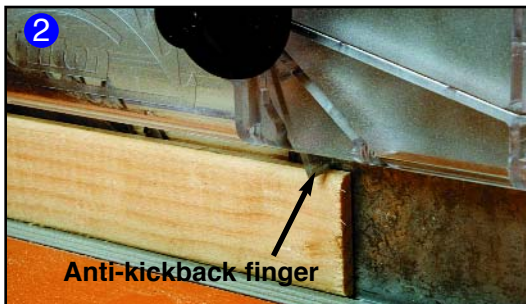

**Never reach over or behind a spinning blade.** Most accidents occur when reaching over an unguarded or poorly guarded blade to remove off-cuts. Push off-cuts away with a stick, or switch off and wait until the blade has stopped spinning before removing them.

**Always use the safety guard when through ripping.** Position the guard support at least 12mm behind the blade at all times. The guard acts as a “splitter” and a “hold-down”, to prevent the wood from flinging towards you. Lower the guard so the anti-kickback fingers are lightly flexed. **2**

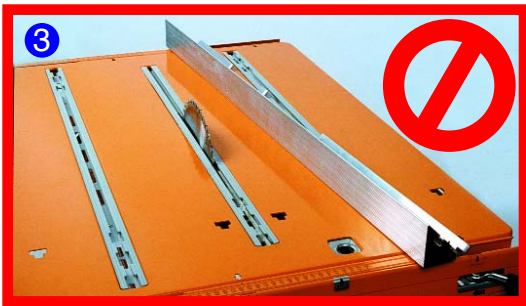

**Always use the rip fence or protractor.** Never attempt a freehand cut (e.g. following a pencil line). The blade can fling the wood towards you with great force if you twist it even slightly during the cut.

**Always set the fence parallel to the blade,** and lock it securely at both ends. You must **never** angle the fence to the blade for rip cuts. **3** Your wood will jam against the blade, and could be flung out towards you.



**Always control the piece between the blade & fence.** If uncontrolled, this piece could get damaged by the side of the blade, or be flung out towards you - especially with short workpieces. Use the pushstick rather than your fingers, unless you have good hand access between the fence and the guard.

To rip a 70mm piece down to 60mm, it's much safer and more accurate to set the fence at 60mm, and have the offcut fall harmlessly aside, **4** than to set the fence at 7mm (allowing for a 3mm saw cut) and have a narrow offcut trapped between the blade and the fence. **5**



**Always wear eye & ear protection.** Serious accidents occur when operators get sawdust or chips in their eyes during a cut. Use ear muffs, and a dust mask or a dust collection system.

For generally smoother cuts with less splintering, lower the blade until it is just a few millimetres through the work. You can further improve cut quality by ripping 1mm oversize, then resetting the fence and making a finishing cut, **6** putting less load on the saw and blade.

Set up the Workcentre on level ground, and kick the legs diagonally outward to ensure it is stable. Check that it is correctly set up (as described on Page 12 Ripping Test).



## RIPPING LONG PIECES

When ripping long pieces which will overhang the rear of the table by more than half their length, either have a friend help you, or rig up a “tail-out” support. The Triton Multi-Stand (MSA200) is ideal for this as it will not steer the work away from the fence. ①

If using a conventional roller stand make sure it is exactly perpendicular to the direction of feed, or it *will* steer your work.

Try to keep the workpiece moving, even slowly, during a long rip. Pauses can cause slight steps in the cut. A finishing cut should help.

## RIPPING LARGER SHEETS



Set the fence on the left, and lock it parallel, although you can add between 0.5 - 1 mm to the rear fence setting for clearance.

Lower the overhead guard as a “hold-down”, lightly flexing the anti-kickback fingers. Push the work against the fence with the left hand, and support the off-cut with your right. Keep both hands on your work and switch off with your knee when you finish the cut.

The Triton Multi-Stand is ideal for supporting larger offcuts. You can clamp a length of wood in the head for even better support. ②



For ripping very large sheets, consider the Triton Sliding Extension Table (ETA200) or use the saw hand-held. Remove it from the chassis, undo the trigger strap, and check the saw guard. Clamp a guide to the workpiece, which should be supported securely on packers.

When ripping thin, flexible material wider than around 500mm, you will need additional support, such as the batten shown ③ to stop the front corner of the material becoming snagged by the rear fence arm.

## RIPPING THICK WOOD



Double your maximum depth of cut by turning the wood over, end for end, and making a second cut. If the edges were dressed square, the two cuts should be in line. ④

The overhead guard cannot be fitted for the first cut. Prevent the wood from riding up on the blade and **feed slowly**. Be careful of your hand positions. They must stay clear of the blade even if the wood kicks back. The guard must be fitted for the second cut.

Adjust the blade height so you'll make two equal-depth cuts... eg. set it at 46mm for double ripping 90mm material





## PLANING AN EDGE

A tungsten carbide tipped blade or a planer blade can give an excellent finish on poorly dressed, weather-stained or painted material. Measure the workpiece - say 90mm wide - and set the fence at 88 or 89mm, to remove 1 or 2mm.

Use the side pressure finger and guided push-stick to hold and control the workpiece, especially when planing narrow pieces. ① Keep the blade as low as possible. Try not to pause during the cut, and do a finishing cut if desired at a slightly narrower fence setting.

Never attempt planing cuts which involve moving the fence very close (1-2mm) to the blade.

For planing a bowed workpiece, attach a straight piece of scrap to the bowed piece so it overhangs one edge for the full length. (Use brads or strong double-sided tape). Run the scrap along the fence, dressing one edge of the bowed piece straight. Remove the piece of scrap and then run the straightened edge against the fence.

## PLANING A WIDER FACE



If planing a face wider than your maximum depth of cut, set up as described above, and make two planing cuts, turning the workpiece over (end-for-end) after the first cut. Use the side pressure finger to hold the workpiece against the fence. ②

Try to make both cuts of similar depth. i.e. plane a 90mm wide face with two cuts of around 46mm.

You will probably not be able to use the overhead guard for the first cut. You must keep the workpiece well controlled, and be very careful of your hand positions. They must stay clear of the blade even if the wood kicks back. The guard must be fitted for the second cut.

## EDGE REBATING

By lowering the saw blade and adjusting the fence, you can make a wide variety of rebates.

When cutting wood which is rectangular in profile always make the first cut with the wood on edge ③ and the second cut on the flat. ④ Otherwise, if rebating narrow wood, the workpiece could end up balancing unsafely on a narrow rebate after the second cut.



You cannot use the overhead guard on these cuts, so make sure your hands stay clear of the blade, even if the wood kicks back.

Most rebates create a narrow off-cut. You should avoid trapping the off-cut between the blade and the fence by doing the cut as shown in ④. If you do have a narrow offcut between the blade and the fence, do not stand directly in line with the blade. The off-cut could be flung towards you at high speed.

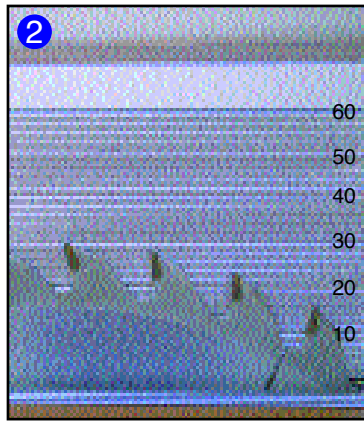
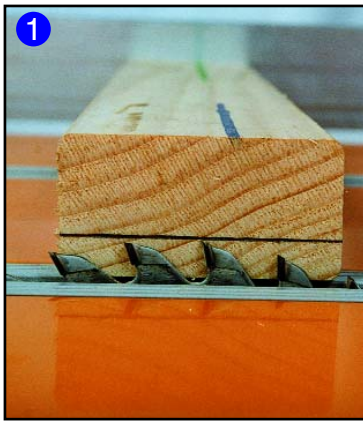

To set the blade to a desired depth of cut, mark it on a piece of wood. Lay the wood beside the blade, leaving both hands free for adjusting the saw. **1** Or use the 2mm & 10mm calibration marks on the face of the rip fence for setting blade height.

In **2** the blade is set to 30mm, the third deep groove up from the table. (These calibrations are approximate only and should be verified by a test cut on some scrap.)

## TONGUE & GROOVING



Study the previous section on Edge Rebating. Make two identical rebates from opposite faces of the workpiece, leaving you with a central tongue. Complete the tongue with the wood lying down flat as shown in **4**, Page 17.

To make a matching groove, move the fence outwards (by one blade width from the tongue setting) and make two cuts from the opposite faces. **4**

Raise the blade 0.5mm before cutting the groove, to allow for glue and to ensure a tight joint.

Always make the first two cuts into the narrower edge of the workpiece **3**, and the two final cuts with the workpiece lying down flat (as in **4** on Page 17). Otherwise, your workpiece could be left balancing unsafely on the narrow tongue after the final cuts.

Test fence and blade height settings on short off-cuts of the wood you'll be using. If joining long pieces (which might not be dead straight), make the test pieces a slightly loose fit. Otherwise you could have problems cramping the job up tightly.

## EDGE WORK ON THIN MATERIAL



If rebating or tongue & grooving very thin boards, the workpiece could be unstable standing on its narrow edge.

Attach a suitable height sub-fence to the rip fence for extra vertical support. (Use strong double-sided tape - 50mm carpetlaying tape is ideal - or countersunk bolts and nuts by removing the fence end caps.) If necessary use a piece of ply or hardboard with a thin slot in it for the blade. Securely tape it to the table as a mask, and have the blade protruding as little as possible. **5**

You cannot use the overhead guard so be very careful with your hand positions.

## WORKING ON ENDGRAIN



Attach a straight, board (100-150mm wide and 25-35mm thick) to the rip fence as described above.

Make a guided “rider”, using an offcut of the same board with cleats on both sides to slide snugly along the top of the board. ① Attach a pusher block to hold the workpiece vertical as you push it over the blade. Or clamp the workpiece to the pusher block.

If making splined right-angled joints ② or splined butt joints ③, cut all pieces from opposite faces, without changing the fence setting, to ensure the grooves line up.

When working with narrow wood, make sure the workpiece cannot jam in the blade slot. Use a mask taped to the table as in *Edge Work on Thin Material*, Page 18.

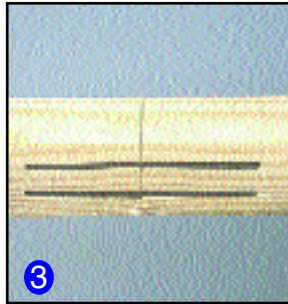

## TAPER RIPPING

**NEVER ANGLE THE FENCE TO THE BLADE FOR TAPER RIPPING.** Taper cuts cannot be made in this way and are extremely dangerous if attempted.



To rip tapers, the workpiece must be angled *by a guide that travels parallel to the blade*.

For short tapers (400-500mm long), you can use the protractor as your guide. The right hand table slot can be used for wider pieces. Hold the workpiece tightly against the sandpaper face and down on the table.

Make sure the overhead guard is fitted and correctly lowered, because your fingers will be passing quite close to the blade. ④

The width of material you can handle is limited and you may have to attach a packer to the protractor face to achieve a desired cutting line. The workpiece should be attached to the packer (using double sided tape or mechanical fasteners). Or fit a rear pusher block to the packer.

Rehearse these cuts with the blade dropped below the table level, and the overhead guard removed, to check your hand positions. Do not rely on the first few millimetres of track at either end of the table for completely accurate guidance.

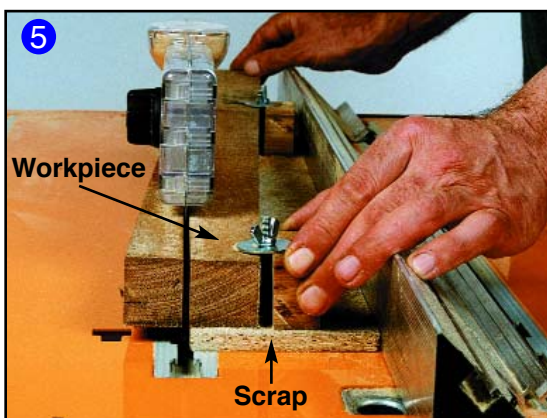

For longer or wider tapers, use a thin piece of parallel-sided scrap as your guide. Attach the workpiece at the desired angle. Slide the scrap against the fence, which is set parallel to the blade. If the scrap was cut to say 100mm wide, set the fence at 100mm, to give good back-up support directly beside the blade.

Use brads or strong double-sided tape to attach the workpiece, or use countersunk bolts, wing-nuts, large washers and offcuts to clamp it to the scrap as shown in ⑤.



## BEVEL RIPPING AT 45°

Turn the rip fence around and turn the fence arms around so that they enter the end panel tracks first. The 45° face of the rip fence will now be facing the blade with the fence still on the left.

Fit the overhead guard support about 30-32mm behind the blade.

**Make sure the blade is at full height and that the slide chassis is locked underneath the table.**

Move the fence in close to the blade and lock it at about 11mm. Loosen the Phillips-head screws and adjust the bevel guides so they give your workpiece maximum support in front of and behind the blade, and behind the overhead guard support.

**With the power disconnected, spin the blade by hand to make sure it clears the guides.**

Fine-tune the fence settings to ensure that the left hand face of the blade is exactly lined up with the internal bottom corner of the guide. This is important for cutting to a perfect “feather” edge without losing any width of workpiece.

Fit and adjust the guard so the workpiece can pass underneath. **1**



Your hand positions, and the amount of pressure you apply, are important in achieving straight, step-free bevels. Avoid pressing down where the workpiece is unsupported - for example at the very end of the cut, when the workpiece moves off the front bevel guide. Adjust the front guide so that the blade enters the notch. **2** It will help prevent “dipping” at the end of the cut. Practice on scrap material first.



If bevelling narrow pieces, the guides give no support while the wood is alongside the blade. Clamp a straight piece of wood squarely to the workpiece, **3**, and use it as a guide running along the top of the fence to support the workpiece at all times.

The Workcentre fence should only be used for cutting pieces of a manageable size - up to say 300mm wide. For larger pieces either obtain the optional Bevel Ripping Guide (BRA200) **4** or use the saw hand-held with the work supported on battens.

Bevel cuts in the full range 0 - 45° can be made in the Crosscut mode (Page 26), provided the workpiece is less than say 500mm wide (depending on your saw size.)



## CHAMFERING AT 45°

You can also use the guides for 45° chamfering. Retract the front guide, so that you can move the fence outwards - say to a setting of 20mm. Lock it exactly parallel.

Observe the above instructions regarding hand positions and hold-down pressures. **If chamfering thick wood, adjust the front bevel guide all the way in to give maximum support beside of the blade. 5**



## CROSSCUTTING IN TABLESAW MODE

Make sure the protractor slides freely in the slot, with both knobs tightened and the protractor set at 0°. Lubricate the slider strip, using spray lubricant such as WD40. Lower the guard to about 5mm above the wood.

Hold the wood firmly against the long face of the protractor, and down on the table, and move it smoothly past the blade. ①



Keep fingers well clear of the blade. Make sure the workpiece is of manageable length, and that the offcut you'll create is well supported after the cut.

Having the protractor behind the work ① is the preferred operating position, but it limits your crosscut capacity to around 140mm. Having the protractor in front of the work ② increases the width capacity to around 340mm. For even wider pieces, you should convert to the crosscut mode.



The first few millimetres of protractor travel in the slots (near the entry holes) should not be relied on for completely accurate guidance.

**NEVER SET THE FENCE AS A STOP ③.** The offcut trapped between the blade and the fence is uncontrolled, and will be flung out towards you, causing possible injury and damage. To do this safely, read on.



## MULTIPLE CROSSCUTTING

If you want to crosscut a number of short pieces to the same length, you *can* safely use the fence as a stop, but you must have a spacer at least 19 mm thick attached to the front of the fence. Set the fence to the desired length of the pieces, plus the thickness of the spacer. ④

By attaching the spacer (using double-sided tape) in front of the blade, the cut-off pieces have room to move, and are not trapped between the blade and the fence.

If you are cutting very small pieces, you may find that they tend to vibrate along the side of the blade, suffering slight re-cut damage. It is better to cut them against a backstop, as described below.

## MULTIPLE CROSSCUTTING AGAINST A BACKSTOP

Attach a sub-fence to the protractor, and clamp a stop block to it. By fully backing up the workpiece and the off-cut, you can keep firm hand control over both pieces. ⑤ For very small pieces you can control the off-cut with a “hold-down” finger fitted to the sub-fences or to the stop block.



For the sub-fence, select a piece of wood (70 x 35, say) which when laid flat is low enough to use the overhead guard, and yet still strong after the blade cuts part-way into it. ⑤

After finishing each cut, make sure you pull the protractor back towards you, well clear of the blade, before removing the off-cut.

## TENONING



Lower the blade. Place the end of the workpiece against the fence, and hold it against the protractor, set at  $0^\circ$ . Make a series of cuts, moving the workpiece away from the fence by one blade-width after each cut. Repeat on the other three faces, and you should have a perfectly central tenon. ①

If using a router to make the mortices, select the cutter first (say 19 mm diameter) and make your tenons 19 mm wide to suit. It will make the morticing easier.

## MITRE CUTTING

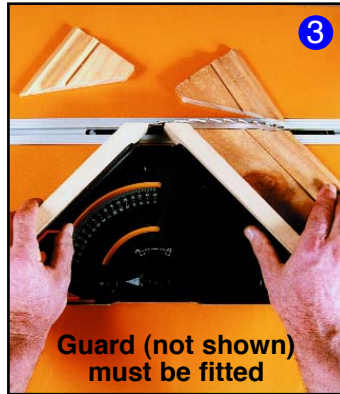
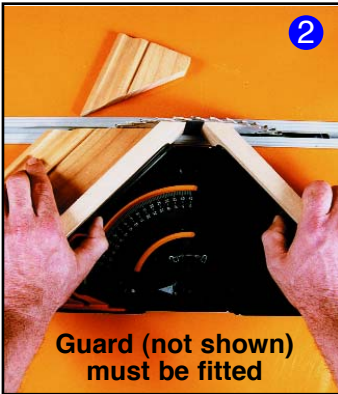

Set the protractor at  $45^\circ$ . Make sure both knobs are tightened and that the protractor slides freely. Hold a straight piece of wood against whichever face of the protractor best supports the workpiece near the blade.

Hold the wood firmly against the protractor during the cut, otherwise it will tend to “creep”.

The protractor can be used in either of the two outer slots, and either way around to suit your job.

Fit subfences (400-500mm long) to the protractor ② & ③ for good workpiece support and a precise means of lining up your cuts. Face them with glued-on sandpaper strips.

Cut about 150mm off the end of a piece of scrap. Place the offcut against the main piece and see if they form a perfect right-angle. If necessary, adjust the protractor angle slightly.

If the wood you are cutting is flat on both faces, cut the reverse mitre at the other end by turning the piece end-for-end, and lying it on its back for the second cut. Or preferably, cut the reverse angle on the adjacent face (as shown in ④ & ⑤). See explanation in blue text below.

## MITRE CUTTING MOULDING



If the workpiece cannot be turned over, (e.g. moulded picture framing or beading) make the first cut with the workpiece held against one  $45^\circ$  face of the protractor ④, and cut the reverse angle mitre with it held against the other  $45^\circ$  face. ⑤

Mouldings should always be cut with their flat base resting against the table, and the taller edge against the face of the protractor. Because the moulded face is always upwards, there will be less visible splintering.

The two shorter faces of the protractor form a perfect right angle. So a piece cut against one face, when placed against a piece cut against the other face will always form a perfect right angle, whatever the angle. For example, if the protractor was accidentally set at  $44^\circ$ , the other face would give you  $46^\circ$ , totalling  $90^\circ$ .

Similarly,  $30^\circ$  off one face will give you  $60^\circ$  off the other. By selecting the correct angle, you can use this method when mitre joining pieces of differing widths.

## MITRE CUTTING TO A LENGTH STOP



To ensure perfect length accuracy when mitre cutting, fit an extension sub-fence (or two) to the protractor, and clamp a mitred block to one of them. ①

Cut the first mitre against the face which does not have the stop, and then place the mitred end against the stop block, for the reverse angle mitre. Both cuts can thus be made with the moulded face upwards, for less visible splintering.

Grip the workpieces firmly because there is a tendency for them to “creep”. It’s a good idea to glue sandpaper to the face of the sub-fence(s).

If you are making square or rectangular frames, cut all of your pieces to a length stop to ensure that each frame comes out perfectly square, with tight corners. Your protractor must be set at exactly 45°.

## CUTTING SHARP POINTS OR WEDGES

Sharp stakes, pegs or wedges can be safely cut on the Workcentre by using the long face of the protractor - set at say 10° - and making two or four cuts, turning the wood over after the each cut.

You must use an extended sub-fence ②, because the protractor face does not give sufficient support - especially after the first cut. Also your fingers would have to pass too close to the blade for safety without the sub-fence.



Preferably butt the far end of the workpiece up against a stop block attached to the sub-fence. It ensures the points will be central without measuring, marking or sighting up, and makes it easier to hold the workpiece. If the workpiece is too long to fit a sub-fence and stop block, you can sight up cuts by using a line squared around each workpiece - say 100 mm in from the end - and referencing it to a pencil mark on the sub-fence. ②

If the workpiece is heavy, or over about 750mm long, cut it in the crosscut mode.

19 x 45mm (2” x 1”) on edge is an ideal size for a sub-fence. Chamfer or rebate the end to allow full height adjustment for the overhead guard.

Adjust the overhead guard so the workpiece just passes underneath and keep the blade as low as possible. Lower the blade to below table level and rehearse this cut without power to confirm your hand positions.

Be careful of the small wedge-shaped off-cuts. They can vibrate into the blade and become re-cut or flung out, or they can become wedged in the table slot beside the blade. Keep a stick handy to move them away from the blade after each cut. If one becomes wedged in the slot, stop cutting, switch off, and wait until the blade stops completely before removing the jammed off-cut.

# OPERATING - Crosscut Mode

Always wear eye protection. Hearing protection and a dust mask are also highly recommended.



## RECOMMENDED OPERATING POSITION

Stand near the switchbox, on the right hand side of the Workcentre as shown. ① Hold the workpiece with your right hand and push the saw with the left. Even though this stance may seem unusual at first, it gives better control over the workpiece, and will soon feel quite natural.

Do not operate the Workcentre from the left hand side as shown in ②. Your hand access is limited, and you cannot hold the wood close to where it is being cut.



Make a test traverse of the saw, with the power switched off, before inserting the workpiece. Do this whenever you've adjusted the saw blade angle or raised the table - for example after using the Workcentre in the overhead router mode.

Always keep hands outside the bearing channels and well out of the path of the blade. Hold the workpiece firmly or use clamps if necessary. Make sure the workpiece and the offcut are well supported, during and after each cut.

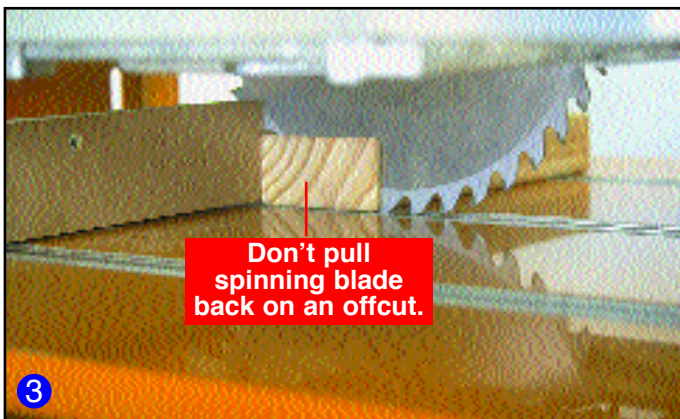

Do not pull the saw back towards you until the blade has stopped. You could hit the offcut with the back of the blade, and cause possible damage or injury. ③

If the back of the blade slightly re-cuts the workpiece as it's slowing to a halt, remove the workpiece sideways as soon as the blade has cut fully through.

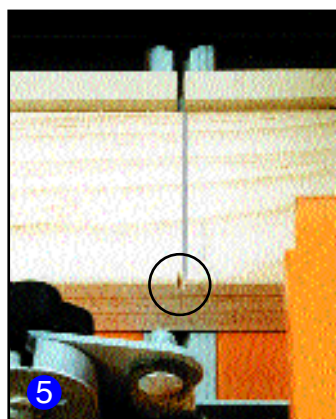
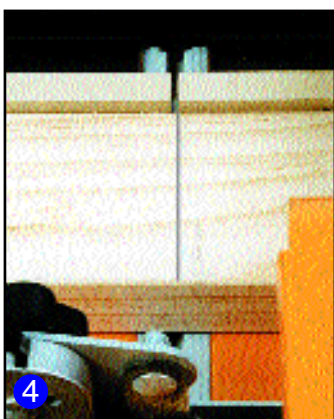

Use the cut that you made in the MDF sub-fence to sight up your future cuts. Place the pencil mark on your workpiece to the left or right side of the cut mark, depending on which side of the line you want to cut. ④ Periodically adjust the sub-fences inwards and re-cut the ends for accurate lining up.

A test "nick" (circled) on the edge of the wood is a useful way of seeing whether your wood is in the right spot. You can then move it slightly one way or the other before making the proper cut. ⑤





## MULTIPLE CROSSCUTTING

If cutting two or more pieces to the same length, rough-cut them to length, a little longer than you'll need. Then line up the dressed ends, and cut the other ends in one pass. You could tape the pieces together if you wish. ❶

You only need to measure and mark one of the pieces - the one closest to the MDF sub-fence - all the pieces will be cut to exactly the same length.

## REBATING (DADOING)

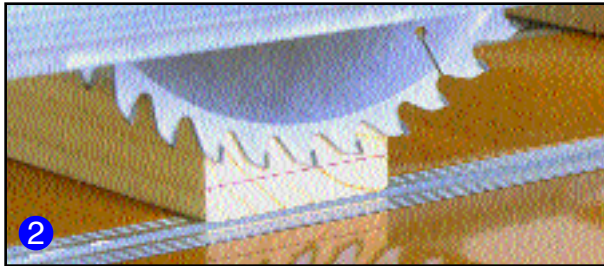

If you only want to partially cut through a workpiece, simply raise the blade and make a series of cuts.

To set the blade to a desired height, raise or lower it until the lowest tooth is just level with a line drawn on a piece of scrap sitting on the table. This allows you to use both hands to adjust the saw, rather than having to hold a ruler as well. ❷

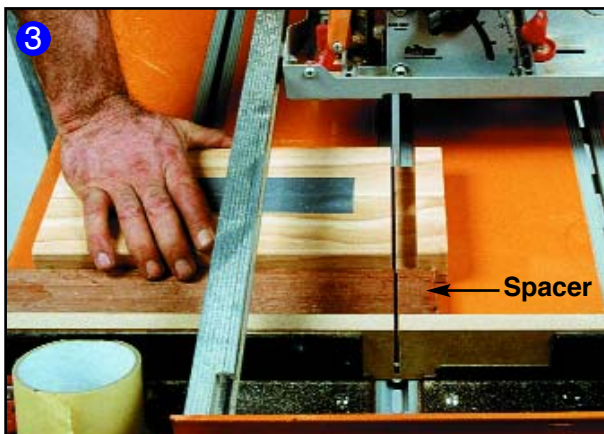

Move the piece(s) sideways by one blade-width after each cut. If cutting several pieces, tape them together.

**Pull the saw back fully clear of the wood before moving the wood sideways.**

Try putting a parallel-sided packing spacer, ❸, say 100-200mm wide, between the workpiece and the crosscut fence. It will bring the work closer to you and you'll avoid back strain. If you have a saw with a long baseplate, a packing spacer may be needed in any case to complete the rebate.

## DOUBLE CUTTING



For cutting wood thicker than your saw depth of cut, you can lower the table. Mark your current table settings with a marker pen, and lower the table support rails at the front and the rear panel. The calibration scales reflect the thickness of wood that can be inserted, i.e. for 90 mm timber, set the red markers at around 92 mm.

The table should be lowered from the normal position by the same amount at all four corners, even if you've built in a compensating slope. (See Saw Slump section on Page 13)

Cut the workpiece a little more than half-way through. Then turn it over and make the second cut. ❹

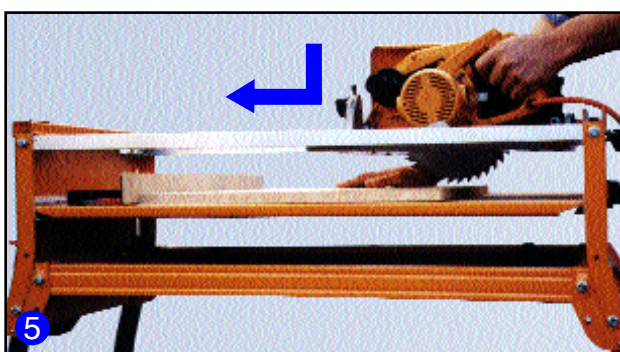

## PLUNGE CUTTING

You can increase the width of cut in the crosscut mode by raising the blade to admit a wider board. Switch on the power, plunge the spinning blade down on the work, then continue the cut as normal. ❺

Make sure the saw's safety guard is held back by the rear of the slide chassis or by a rubber band, string etc. Do not attempt these cuts unless the saw raises and lowers smoothly, and reasonably accurately.

## CROSSCUTTING WIDER WORKPIECES

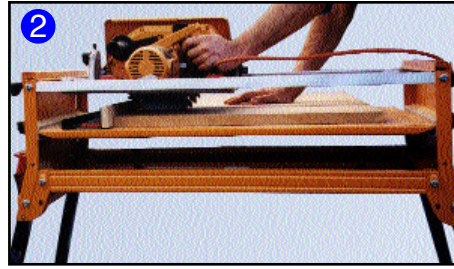
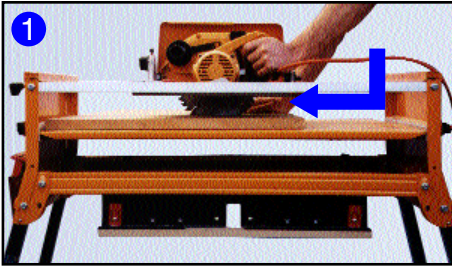

For workpieces up to 680mm wide, remove the crosscut fence and rest the workpiece against the rear table support rail. Plunge in and cut as far as you can. ❶ Switch off and wait until the saw stops. Pull the saw and work towards the front panel. Fit the crosscut fence, line up the blade centrally in the kerf, and complete the cut. ❷

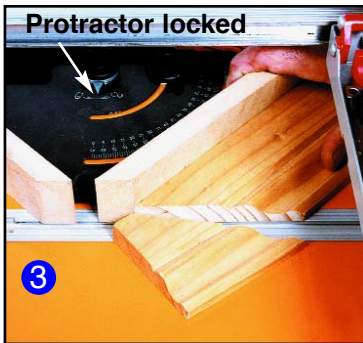

## MITRE CUTTING

Remove the crosscut fence (if necessary), and fit the protractor to the right hand table slot. Lock it in in the slot by loosening the central knob and turning the pointer to the  $\square$  position. ❸ Tighten the knob.

Set the desired angle using the knob near the scale and lock it tightly.

Hold the workpiece **firmly** against the sandpaper face and make the cut. Let the blade stop spinning before pulling the saw back. Always ensure the protractor is providing support next to the blade slot.

Sight up mitre cuts by opening the side guard and touching the stationary blade against the cutting mark. Alternatively, attach sub-fences to your protractor as in ❸ & ❹. The  $45^\circ$  trimmed ends will be your sighting reference.

## BEVEL MITRES (COMPOUND CUTS)



Remove the crosscut fence and lock the protractor in its slot, set at the required angle. Tilt the blade to the desired angle. **DO NOT RAISE THE TABLE**, as the blade is no longer above the slot. Use thin packing under the workpiece to raise it up to the blade. ❺

Hold the workpiece firmly against the angled protractor face, and keep fingers well clear of the blade. Avoid twisting the handgrip of the saw as you push.

**Bevel cuts put a lot of load on the workpiece and the saw. Make sure the workpiece doesn't creep during the cut.**

If you have arbor float in your saw, or a poor blade, make a second shaving cut.

If the packing is clamped to the table, the blade score line can be used for lining up future cuts.

## BEVEL CUTTING



Study "Bevel Mitres" above, but use the crosscut fence rather than the protractor to rest the wood against.

**Before making a cut, check that the blade will not hit the crosscut fence or any part of the table or aluminium track. Hold the wood firmly as it will tend to move sideways.**

Make a dedicated platform for bevel sawing. ❻ It has shallow strips glued under both edges, 644mm apart, for a snug fit on the table. The score line in the platform, and the  $45^\circ$  cut in the MDF fence will provide reference marks for lining up cuts. Sandpaper strips glued onto the subfence will help prevent the wood moving.

Cut bevels two or more at a time for length accuracy. Preferably tape them together, as shown.

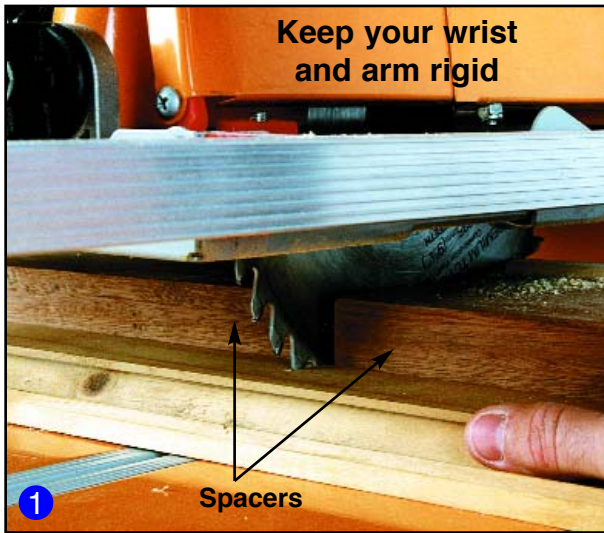

## CLIMB CUTTING

Climb cutting (or pulling the saw backwards into the work) is useful with thin or flexible material, such as fine moulding, which tends to lift off the table when cut normally. You will need a sharp TCT blade and packing spacers (150-200mm wide) between your work and the MDF sub-fences on the crosscut fence. ① Temporarily remove the riving knife (if fitted) from your saw.

**Tightly lock the blade height adjuster. Keep your arm and wrist rigid. The saw will want to “climb” on your work. You must control it firmly.**

A climb cut gives less splintering on the top face, so is also useful for cutting mouldings such as architrave.

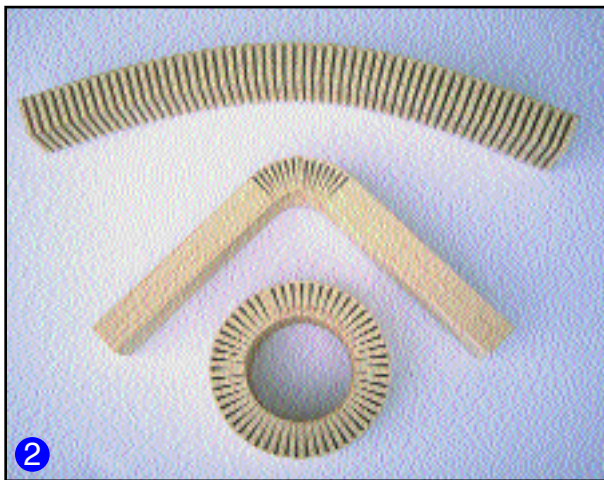

## KERFING (BENDING WOOD)

A series of parallel cross cuts - evenly spaced - almost all the way through a piece of wood enables you to bend it. The radius of bend depends largely on the spacing between cuts.

Experiment with how much to leave uncut: it depends on the species, the grain, and the moisture content. As a rule of thumb, leave between 2mm and 5mm uncut.

For evenly spaced cuts, make a pencil mark the width of the blade on the sub-fence or on a packing spacer ③. Make a cut, move the wood sideways until the cut is lined up with the pencil mark, and make the next cut, and so on.

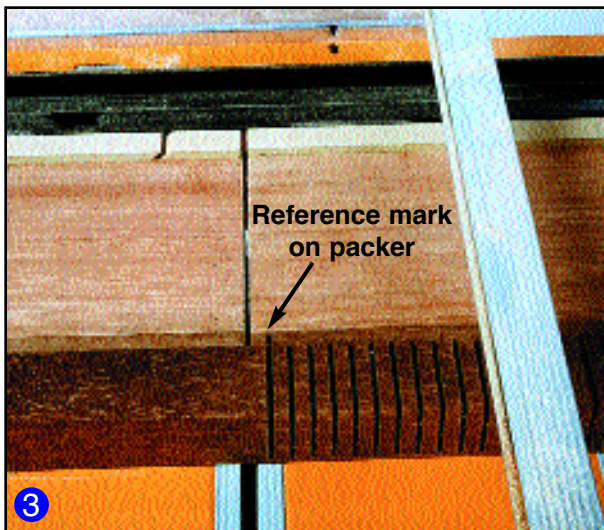

Avoid twisting the hand-grip of the saw. Preferably, lock on the trigger with the trigger strap, control the power via the switchbox, and push the slide chassis rather than the saw.

You may find that 14 cuts, say, gives you less than a right-angle, and 15 cuts gives you more. If you want 90°, try making the first and fourteenth cuts a little wider than the rest, by making a shaving cut beside the normal cut. It will effectively give you 14½ cuts, unobtrusively.

Avoid using knotty, or short-grained material. Ideally use straight grained material with a high moisture content. After cutting, use great care in handling kerfed pieces. Do not bend them backwards. Always close up the cuts. Perhaps make the bend in stages by pinning, clamping or tying it in a gradually tightening radius. Consider using steam to assist bending.

Strengthen a kerf if necessary by filling the cuts with two-pack epoxy, epoxy putty or tinted body filler. For decorative purposes, it generally does not need to be filled, just well glued on the inside face using a high quality PVA glue.

## HANDY STORAGE OF GUIDES

All the attachments for the Workcentre have on-board storage locations.

Fit the overhead guard to the T-slot in the rip fence, fold the arms of the fence inwards, and clip the fence into the fence hangers. The crosscut fence hangs neatly from either of the base channels using its rear lip. ① & ②



The Protractor (G) can be stored on the two red hooks on the rear panel, or can temporarily hang from either of the pushstick hangers on the front panel during a working session. ②

**When finished work for the day. Release the saw safety guard, remove the trigger strap and unplug the saw.**

## DUST COLLECTION

Protect your health and keep your workshop clean by using the optional Triton Dust Bag (DCA250). Connect any vacuum cleaner to the overhead guard hose supplied and collect almost 100% of the dust created in the tablesaw mode.

The Dust Collector (DCA300) prevents saw dust filling up or clogging your vacuum cleaner. It provides a huge 20 litre capacity and can also be used with the Series 2000 Router Table and the Biscuit Joiner.



## CUSTOMER SATISFACTION

We aim for extremely high levels of customer satisfaction. If there's anything we can do to improve our products or services, please let us know. If you're completely satisfied, please tell your friends.

Make sure you get onto our mailing list by returning the enclosed Warranty Registration Coupon. We'll send you details of future product updates and accessories.

**Made in Australia by: Triton Manufacturing & Design Co. Pty. Ltd.** ACN 006 021 683  
14-18 Mills St, Cheltenham, Vic. 3192 Ph: (03) 9584 6977 Fax: (03) 9584 5510  
E-mail: tools@triton.net.au Web Site: <http://triton.net.au>

**Australia: Vic** - (03) 9584 6977 **NSW** - (02) 9822 4111 **Qld** - (07) 3252 7666  
**SA** - (08) 8340 2833 **WA** - (089) 350 5588 **Tas** - (0363) 44 7060

**International Offices:** **Canada** - Free Call: 1 888 874 8661 **Japan** - Free Call: 0120 171 079  
**New Zealand** - Ph: 9415 2545 **South Africa** - Free Call: 0800 600 432  
**United Kingdom** - Free Call: 0800 856 7600

*Due to our company policy of continuous product improvement, specifications may change without prior notice.*