

■ 14.4 V / 18 V CORDLESS DRILL/
DRIVERS & COMBI'S

metabo[®]
work. don't play.

MASTERS AT WORK.



- Extremely high performance, compact size and significantly reduced weight
- Optimum overload protection for battery cells and machine
- Significantly wider range of applications and longer service life



3 YEAR BATTERY PACK WARRANTY



**»TIME IS MONEY. QUALITY PAYS DIVIDENDS.
FOR THAT I NEED GOOD TOOLS.«**

Tradesmen have to be able to rely on their machines. When a device fails during a hard working day on the building site, valuable time is wasted. We understand that time is money so we have designed our tools to perform and last, tools that won't let you down. Our engineers know what is required to deliver a tool that can cope with your needs. That's why we subject our

machines to numerous tests under conditions which are even more demanding than reality. So we can be sure that our new cordless drills will deliver to your expectations. **Metabo. Work. Don't play.**



IN SICKNESS AND IN HEALTH.

FIND OUT MORE ABOUT OUR SERVICES AT WWW.METABO.COM/SERVICES.2034.0.



3 YEAR BATTERY PACK WARRANTY

(more information on the back)

BORN THROUGH DESIGN.

The new L, LT and LTX-class cordless range are masters of their trade. There are many reasons for this: They are high-performance machines and extraordinarily light and compact. The new gear concept with its innovative torque clutch makes

a wider range of applications possible, as the adjustable torque range has been virtually doubled. Thanks to our new motor & battery concept we have been able to make the machines more compact and even more powerful. We have also managed to protect your

Spanner flat for removing drill chucks

Allows you to change the chuck easily (LT and LTX-class).



43 mm collar

For 360degree rotation of side handle. Can be fitted to a drill stand. (LT and LTX-class).

»THE WORK WAS CERTAINLY WORTHWHILE«

Werner Fischer,
Engineer



What was the main focus during development of the new cordless devices?

„While developing the cordless drills, the same criteria always take centre stage: more power, more compact dimensions, lower weight and improved ergonomics. And of course we want to be one step ahead.“

Are you satisfied with the result?

„Everything has worked out well. Above all, the interplay within the project team impressed me. Although I don't want to hide the fact that in a demanding project like our new gear

concept, some things can be a challenge. But together we overcame our obstacles.“

What exactly do the new machines offer?

„There are so many advantages I'll have to keep it short: Smaller motor and housing dimensions, new gear technology, highest-quality battery technology, an electronic and charging technology which works in harmony with the machine, plus improved ergonomics. I don't think we've missed anything.“

Hex bit holder in spindle

Enables chuck free working – a bonus for when you need to screwdrive in tight spaces (LT and LTX-class).

LED work light

Lights up the darkest of working areas

Impuls technology

„Strength boost“ on tricky tasks, such as spot-drilling smooth surfaces or removing damaged screws (LT and LTX-class).



investment and increase service life through our new electronic single cell protection (ESCP) system which protects the battery pack and the machine from overloading. Our tried-and-tested AIR COOLED charging technology means the battery packs are, as usual,

charged gently and quickly. Born through design to give you tools you can trust. For added piece of mind we now provide a three-year warranty on all machines, batteries, chucks and chargers.



New gear concept

An innovative, patented torque clutch with more torque settings increases the range of possible working applications (LT and LTX-class).

New motor concept

High power to size ratio. Extremely high performance motors across the range.

New gear speed switch

Optimally suited for one-handed operation; for right or left handed use (LT and LTX-class).

New electronics concept

Longer service life thanks to electronic monitoring of individual cells (Electronic Single Cell Protection).

Charge level indicator

So you always know how much power you have available before you start a job.

Innovative battery technology

Very high quality lithium ion battery cells for outstanding performance. AIR COOLED charging technology for a quicker charge time and a long battery pack service life.

THE COMPLETE PACKAGE.

We have developed a ground-breaking electronics concept for our new cordless drills. The service life of the machines has thereby been increased, as the individual components continually communicate with each other during the working and charging process. The

integrated electronics prevent damage to the components by permitting certain threshold values to be exceeded (currents, voltages and temperatures) on work peaks, but providing protective intervention upon continual overloading.

New compact motor
If the machine reaches a critical temperature threshold, the electronic unit switches the motor off increasing service life.

Electronic unit
Evaluates the currents, voltages and temperatures occurring as a result of the workload. For the protection of all components the device is switched off upon reaching certain thresholds, thus increasing service life and reducing repair costs.

Battery pack
The battery pack with integrated single cell and temperature monitoring continually transmits the current, voltage and temperature to the electronic unit.

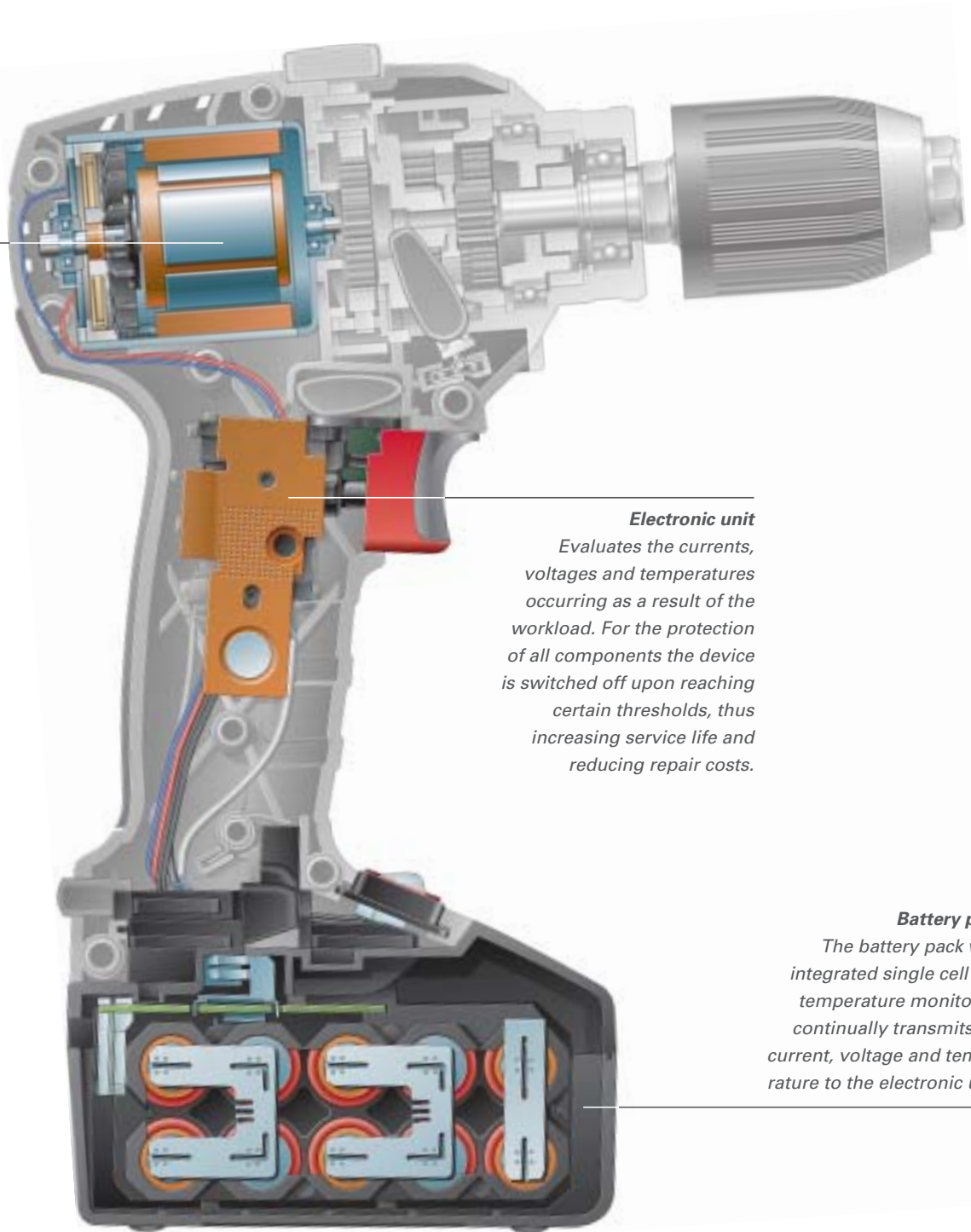

FASTER CHARGING, LONGER LASTING.

With our new cordless drills we have realised a perfect interplay between battery and charging technology. Together with the electronic concept, charging processes are gentler and faster. The individual battery cells are protected by ESCP (Electronic Single Cell

Protection). The three different battery packs Li-Power Compact, Li-Power Plus and Li-Power Extreme provide the optimum performance required for each and every application within their class.



Charge level indicator
Enables continual checks of the current battery pack capacity status.

Highest-quality cells
With the best performance power on the market in their respective class.

ESCP cell monitoring
Electronic Single Cell Protection – protects each and every battery cell from discharging completely while working, and from overcharging during the charging process.

Temperature monitoring system
For constant checks of the battery pack temperature.

Float mounting
The core pack is float-mounted. This gives greater battery cell protection and increased service life.

LONGER SERVICE LIFE THROUGH COOLING

Our proven AIR COOLED charging technology with its innovative guided air flow ducting cools the battery pack during charging to an optimum temperature level. This shortens the charging process by about 30%, the batteries last significantly longer and saves having to wait long periods for your batteries to charge.



MASTER OF FORM.

The design of our new cordless drills has been made even more ergonomic. Their size is significantly smaller and much more compact than before. Additionally, we have made them up to 1 kg lighter (LTX-Class)

reducing operator fatigue during extended periods of use. Because these machines are now even more agile, they are even better for working in tight spaces.

HIGH PERFORMANCE IN THE SMALLEST OF SPACES.

The new motor concept had a main goal: To achieve high performance while at the same time minimising the size. Our success is shown by the figures within the size comparisons. To guarantee a longer service life of the machines, the temperature level must be as low as possible. We implemented that by means of various technical improvements: Optimised ventilation slots and an improved cooling principle, as well as an optimised overload range.



*BS 18 LTX Impuls
vs. predecessor*

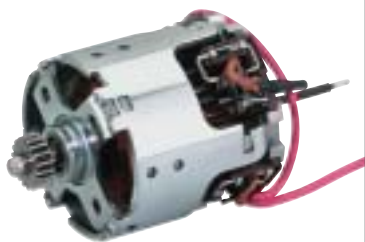

Compact in size

The motors of all the new machines are smaller and lighter than before. This increases their power density even more significantly. (LTX motor shown)



*BS 14.4 Li
vs. predecessor*



*BS 14.4 LT Impuls
vs. predecessor*

NEW CLUTCH – MORE APPLICATIONS.

We have developed a new gear concept for our new cordless drills (LT & LTX Class). The integrated and patented torque clutch system extends the adjustable torque range. In comparison to most other

manufacturers, we have almost doubled the available torque range and created the opportunity to perform applications with our products which were previously impossible.

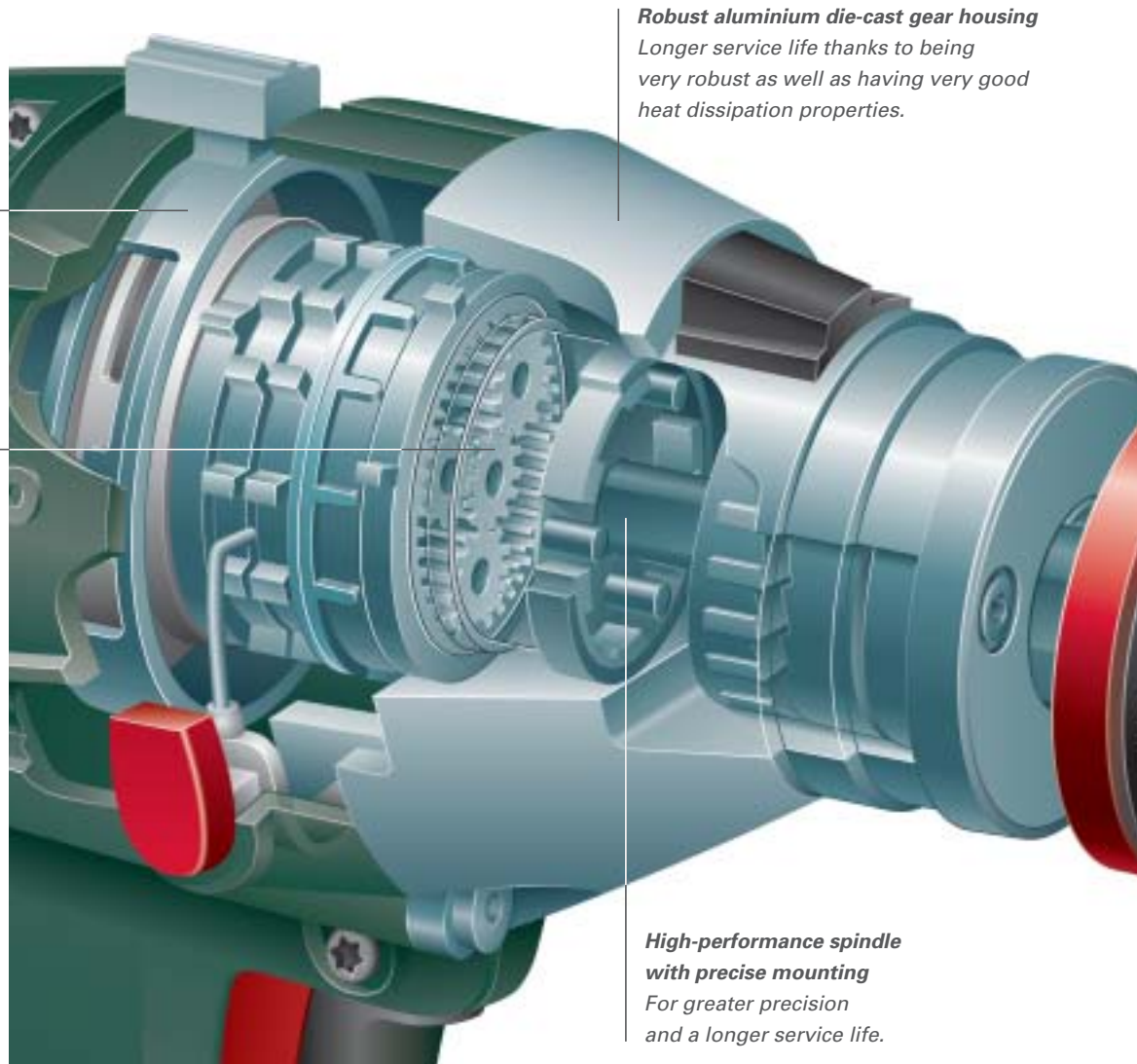

New torque clutch system

Larger adjustable torque range for a wider application spectrum.

Needle bearing planets

The planets on the needle bearing in the new gears provide a higher degree of efficiency, a lower temperature level, longer service life and lower noise emission.

Robust aluminium die-cast gear housing

Longer service life thanks to being very robust as well as having very good heat dissipation properties.

High-performance spindle with precise mounting

For greater precision and a longer service life.



Working without a drill chuck

The hex bit holder in the spindle allows for chuck-free work. This means reduced weight and size – ideal for places which are hard to access. (LT & LTX Class)

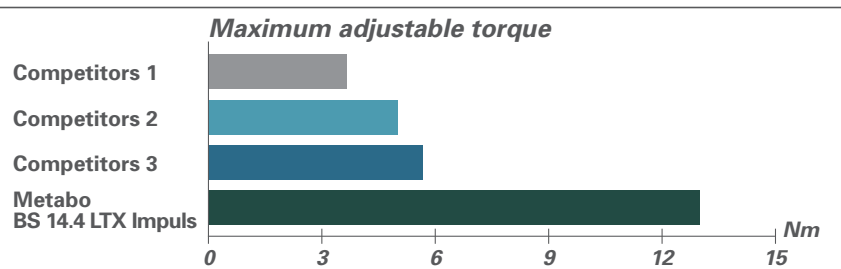

Larger adjustable torque range

The new torque clutch system provides a larger adjustable torque range. This allows the cordless drills to be used for considerably more applications. (LT & LTX Class)

DRILLING IS MADE EVEN EASIER.

The machines in our new L-Class are amongst the lightest in their power class. Being so lightweight yet powerful these machines really are a joy to use. These

cordless drill/drivers are the ideal devices for the smaller tasks e.g. furniture. They are



assembling optimal-

Charge time in minutes

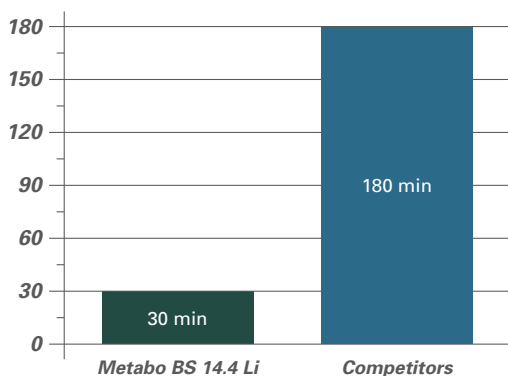

Torque

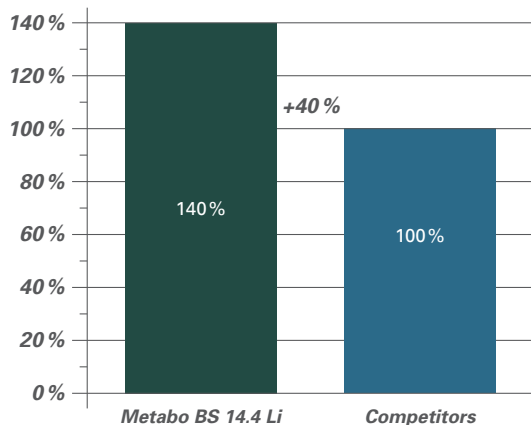

Technical data L-Class

BS 14.4 Li

BS 18 Li



Voltage	14.4 Volts	18 Volts
Capacity	1.3 Ah	1.3 Ah
Idle speed (1st/2nd gear)	0–450/0–1,600 rpm.	0–450/0–1,650 rpm.
Weight incl. smallest battery	1.35 kg	1.4 kg
Torque (soft/hard)	20/40 Nm	24/48 Nm
Drilling diameter in steel (MAX.)	10 mm	10 mm
Drilling diameter in wood (MAX.)	20 mm	20 mm
Order number	6.02135	6.02136

ly suited for screws with a diameter of 6 mm, and are suitable for drilling into wood up to max. 20 mm.



Practical when assembling furniture

The LED light gives you clear illumination of the work area for more confident drilling.



Drilling in metal

With a speed of up to 1,600 rpm, the BS 18 Li is ideal for small diameter drilling into metal.



Always ready

With a charging time of just 30 minutes, unnecessary time waiting for battery's to charge is a thing of the past.



Drilling screws in wood

The L-Class is perfect for trades where a fast, yet light screwdriver is required.



With impact hammer function for walls

The impact hammer function is usually required when drilling into brick, stone or breeze block.



Spot-drilling tiles

The impuls function is ideal for drilling into tiles. It prevents any slipping of the drill by means of a fixed-spot strength boost.



Expanded application spectrum

The new torque clutch means large screws can also be effortlessly screwed in flush.



Ideal for carpentry work

The LT-Class is outstandingly suited for use with the centre bit, e.g. for carpentry work.

THE STRONG AND STURDY TYPE.





The LT-Class is a reliable companion for trade applications such as interior construction and exhibition construction. It is distinguished by its high-power performance, which is unparalleled in this class. With



its Li-Power Plus battery pack and new motor and gear concept plus the innovative torque clutch system, the LT-Class is

fit for the hardest of jobs encountered in everyday work. They are also particularly suited for drilling screws up to a diameter of 8 mm and for drilling holes in wood up to max. 30 mm.



Technical data LT-Class	BS 14.4 LT Impuls *	SB 14.4 LT Impuls *	BS 18 LT Impuls *	SB 18 LT Impuls *
				
Voltage	14.4 Volts	14.4 Volts	18 Volts	18 Volts
Capacity	2.6 Ah	2.6 Ah	2.6 Ah	2.6 Ah
Max. torque [soft / hard]	24/55 Nm	25/57 Nm	26/60 Nm	27/62 Nm
Adjustable torque from to	1.5–13 Nm	1.5–13 Nm	1.5–13 Nm	1.5–13 Nm
Drill bit diameter in				
– wood	30 mm	30 mm	30 mm	30 mm
– steel	13 mm	13 mm	13 mm	13 mm
– concrete	–	12 mm	–	12 mm
Idling speeds (1st/2nd gear)	0–400/0–1,400 rpm.	0–400/0–1,400 rpm.	0–400/0–1,400 rpm.	0–400/0–1,400 rpm.
Max. impact rate	–	28,000	–	28,000
Weight	1.8 kg	1.9 kg	1.9 kg	2.0 kg
Order number	6.02137	6.02140	6.02139	6.02142

* Available as of April 2009

EVEN THE MIGHTY DON'T MAKE IT THIS EASY.

The machines in the LTX-Class are the lightest and most compact in this power class. Their high-performance Li-Power Extreme battery pack and the 4-pole compact motor give these machines maximum

strength. This makes them problem solvers even on the hardest of jobs – when drilling screws with diameters up to 10 mm, and when drilling holes into wood up to max. 50 mm.

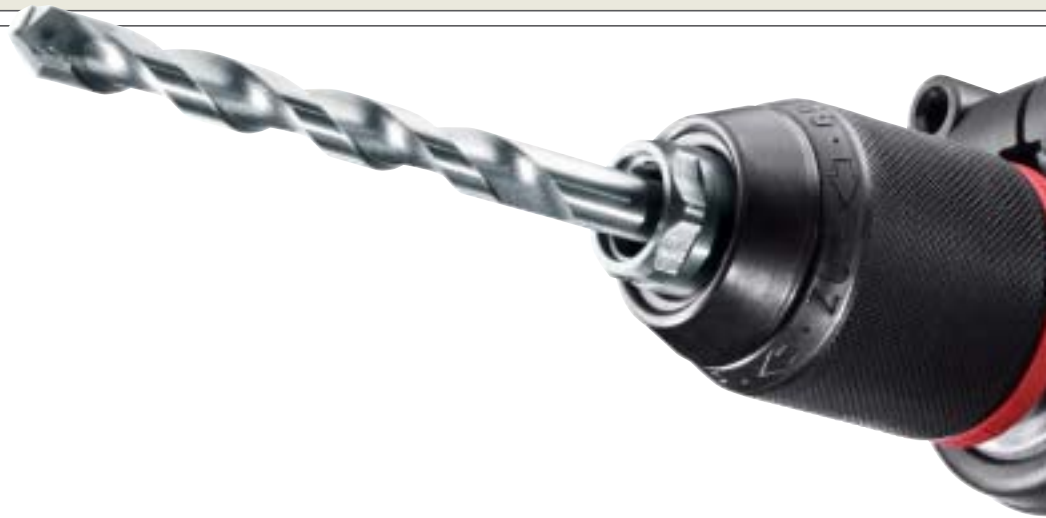

Technical data LTX-Class

BS 14.4 LTX Impuls *

SB 14.4 LTX Impuls *

BS 18 LTX Impuls *

SB 18 LTX Impuls *



Technical data LTX-Class	BS 14.4 LTX Impuls *	SB 14.4 LTX Impuls *	BS 18 LTX Impuls *	SB 18 LTX Impuls *
Voltage	14.4 Volts	14.4 Volts	18 Volts	18 Volts
Capacity	2.6 Ah	2.6 Ah	2.6 Ah	2.6 Ah
Max. torque [soft / hard]	38/88 Nm	40/92 Nm	42/96 Nm	44/100 Nm
Adjustable torque from to	1.5–13 Nm	1.5–13 Nm	1.5–13 Nm	1.5–13 Nm
Drill bit diameter in				
– wood	45 mm	45 mm	50 mm	50 mm
– steel	13 mm	13 mm	13 mm	13 mm
– concrete	–	13 mm	–	16 mm
Idling speeds (1st/2nd gear)	0–400/0–1,400 rpm.	0–400/0–1,400 rpm.	0–400/0–1,400 rpm.	0–400/0–1,400 rpm.
Max. impact rate	–	28,000	–	28,000
Weight	1.9 kg	2.0 kg	2.0 kg	2.1 kg
Order number	6.02143	6.02146	6.02145	6.02148

* Available as of April 2009



With impact function for walls
The enormous strength of the LTX-Class makes impact drilling into brick or stone child's play.



Practical for interior work
The LTX-Class delivers the power needed for installing power points during interior work.



Drill roof beams without problems
Carpenters have the right idea: thanks to optimal motor and gear design, the LTX-Class easily gets into the beams, even with large drill bits.



Large screws in wood
Thanks to a maximum torque of 42/96 Nm even the largest screws can be handled without problems.



3 YEAR BATTERY PACK WARRANTY

THE NEW THREE-YEAR WARRANTY FROM METABO

All new Metabo battery packs now have a three-year warranty. Should your battery pack fail within three years of purchase (please present a valid sales receipt), the battery pack will be replaced free of charge by Metabo. Except if due to improper use. More information on this can be found in the Internet.

ACCESSORIES CORDLESS DRILL/DRIVERS

Universal drill bit storage case



4-piece, in plastic storage case
Ø 5/6/8/10 mm

Order number 6.27185

Screwdriver bit assortments 1/4" (6.35 mm), hexagonal shank



Bit-box with stainless steel bits (10-piece)

Plastic storage case. Consisting of a bit holder „rapid in/easy out“ and the most commonly used bits in woodworking: 2 Phillips bits Size 2, 1 each: Pozidriv bit Size 1, Phillips Size 2, Torx Size 10, 15, 25, 30. Bits and holder are made of stainless steel.

Order number 6.25388

Bit-box with stainless steel bits (10-piece)

Plastic storage case. Consisting of a bit holder „rapid in/easy out“ and the most commonly used bits in metalworking: 2 bits each: Phillips Size 1, Phillips Size 2, 1 bit each Phillips Size 3, Inbus 2.5; 3.0; 4.0; 5.0. Bits and holder are made of stainless steel.

Order number 6.25389

Bit box Torsion (10-piece)

Plastic storage case. Consists of: 1 each: Phillips bit Size 1, 2, 3; 1 each: Pozidriv bit Size 1, 2, 3; 1 bit each for slotted screws; 0.8 x 5.5 mm, 1.0 x 5.5 mm and 1.2 x 6.5 mm bit holder „rapid in/easy out“.

Order number 6.25390

Bit box Torx and Pozidriv (10-piece)

Plastic storage case. Consists of: 1 bit each: Pozidriv, sizes 1, 2, 3 (torsion bits), 1 Torx bit, sizes TX 10, 15, 20, 25, 30 and 40; bit holder „rapid in / easy out“.

Order number 6.25391

Bit box Torsion Universal (10-piece)

Plastic storage case. Consisting of: 1 bit for slotted-head screws 0.8 x 5.5 mm, 1 bit Phillips S. 2, 1 bit Pozidriv S. 2, 1 bit each Torx S. 10, 15, 20, 1 bit each for screws. With hexagonal socket Size 3, 4, 5. Bit holder „rapid in/easy out“.

Order number 6.25396

Bit-box diamond Pozidriv (7-part)

Plastic storage case. Consists of: Pozidriv bits 2 x Size 1, 3 x Size 2, 1 x Size 3 (diamond) bit holder „rapid in/easy out“.

Order number 6.25393

Bit-box diamond Universal (7-part)

Plastic storage case. Consists of: 1 bit each for slotted-head screws 1.0 x 5.5 mm, 1.2 x 6.5 mm, 1 bit each: Phillips S. 1, 2, 1 bit each: Pozidriv S. 1, 2. Bit holder „rapid in/easy out“.

Order number 6.25397

